

GLOBAL JOURNAL OF ENGINEERING SCIENCE AND RESEARCHES
AERIAL ROBOTICS WITH ARTIFICIAL INTELLIGENCE, DESIGN AND
APPLICATIONS
VISHNU .V. NATH

Calorx Teacher's University, Ahmedabad - 382481, Gujarat

ACKNOWLEDGEMENT

First of All I want to express my heart full thanks to Supervisor of my Ph.D. research work Dr. GARG, Calorx Teacher's University, Ahmedabad. He helped me in every stage of my research work and sincerely guides me about all the issue and new dimensions of research work. I am thankful to all faculty members of department of computer science & electronics engineering. I am dedicating this thesis to my parents, P B Venu Nath, R Sivakumari and my brother Vinu V Nath.

I. INTRODUCTION

An AERIAL ROBOTIC platform can achieve vertical flight in a stable manner and be used to monitor or collect data in a specific region such as mapping terrains, agriculture planning, remote sensing, disaster management, waste management, cellular network planning, nuclear accident inspection etc. Technological advances have reduced the cost and increase the performance of the low power microcontrollers that allowed developing their own platform. The aim is to design multicopter to obtain stable flight, gather and store GPS data, and perform auto-commands, and implement AI for classifying requested data from cameras and other sensors. The project uses a frame, motors, electronic speed controller, flight controller board, sensor boards and individual components were tested and verified to work properly. Calibration and tuning of the PID controller was done to obtain proper stabilization on each axis. This platform uses four or eight rotors for lift, steering, and stabilization. Unlike other aerial vehicles, the quadcopter can achieve vertical flight in a more stable condition. The quadcopter is not affected by the torque issues that a helicopter experiences due to the main rotor. Furthermore, due to the quadcopter's cyclic design, it is easier to construct and maintain. As the technology becomes more advanced and more accessible to the public, many engineers and researchers have started designing and implementing quadcopter for different uses.

II. MOTIVATION AND PROBLEM STATEMENT

The primary scope of this thesis is the development of new and advanced methods in support of control system development for Unmanned Aerial Vehicle control and customizes UAV for different applications. I have been an active RC pilot from my college days, therefore, as soon as I've got acquainted with engineering practice, the subject of UAV design and customization has been one of my main occupational interests. Thus, being able to design, pilot the UAV gives me a lot of motivation for my research. As the focus of aircraft control system development is steadily expanding towards unmanned systems, the results of this research can be used as viable solutions to a particular set of challenges encountered in the primary phases of UAV control algorithm design

The main research objectives of the thesis are as follows

1. Design and develop UAV for payload up to 200g, 1kg and 15kg with maximum flight time with appropriate frame, motors, ESC's, and flight controller.
2. Develop a multicopter UAV system for land surveying, precision agriculture, reconnaissance, disaster management including nuclear accident inspection.
3. Incorporate NDVI (Normalized Difference Vegetation Index) camera to measure the amount of live vegetation in agriculture field along with nutrients spraying mechanism that spray nutrients proportional to the plant health data from NDVI images.
4. Test the feasibility of using thermal imaging for life-saving application.

5. Incorporate a pay-load releasing mechanism from a remote control signal.
6. Incorporate face detection using machine learning.
7. Design a heavy payload human carrying aerial platform.

III. LITERATURE REVIEW

3.1 History

Multicopter history Etienne Oehmichen was the first scientist who experimented with rotorcraft designs in 1920. Among the six designs he tried, his second multicopter had four rotors and eight propellers, all driven by a single engine. The Oehmichen used a steel-tube frame, with two-bladed rotors at the ends of the four arms. The angle of these blades could be varied by warping. Five of the propellers, spinning in the horizontal plane, stabilized the machine laterally. Another propeller was mounted at the nose for steering. The remaining pair of propellers was for forward propulsion. The aircraft exhibited a considerable degree of stability and controllability for its time, and made more than a thousand test flights during the middle 1920. By 1923 it was able to remain airborne for several minutes at a time, and on April 14, 1924 it established the first-ever FAI distance record for helicopters of 360 m. Later, it completed the first 1 kilometer closed-circuit flight by a rotorcraft.

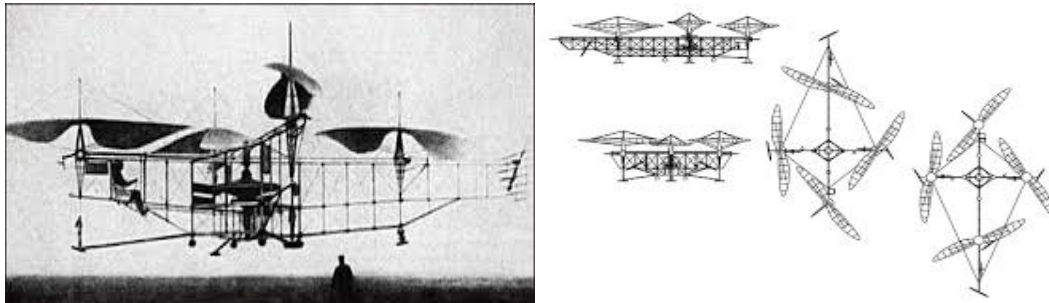

Figure 3.1 Oehmichen's multicopter. source google

After Oehmichen, Dr. George de Bothezat and Ivan Jerome developed aircraft, with six bladed rotors at the end of an X-shaped structure. Two small propellers with variable pitch were used for thrust and yaw control. The vehicle used collective pitch control. It made its first flight in October 1922. About 100 flights were made by the end of 1923. The highest it ever reached was about 5 m. Although demonstrating feasibility, it was underpowered, unresponsive, mechanically complex and susceptible to reliability problems. Pilot workload was too high during hover to attempt lateral motion.

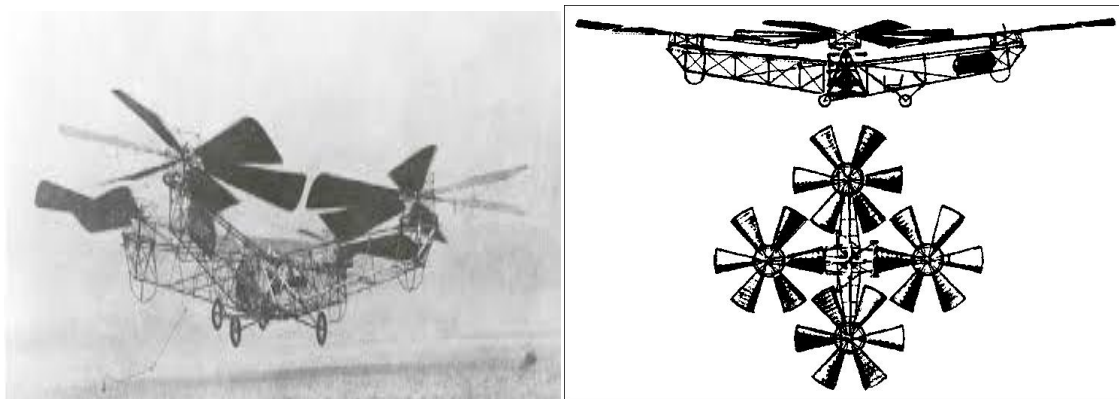

Figure 3.2 The de Bothezat Multicopter. source google

Convertawings Model A Multicopter (1956) was intended to be the prototype for a line of much larger civil and military multicopter helicopters. The design featured two engines driving four rotors with wings added for additional lift in forward flight. No tail rotor was needed and control was obtained by varying the thrust between rotors. Flown successfully many times in the mid-1950s, this helicopter proved the multicopter design and it was also the first four-rotor helicopter to demonstrate successful forward flight. However, due to the lack of orders for commercial or military versions however, the project was terminated. Convertawings proposed a Model E that would have a maximum weight of 19,000 kg with a payload of 4,900 kg.



Figure 3.3 The Convertawings source google

IV. SYSTEM MODEL

The system incorporates several subsystems working in union for communication and control. The quadcopter uses a STM32 microcontroller running an embedded Linux operating system and uses a wireless serial link to receive commands and transmit data. Its GPS location, as well as streaming video, is transmitted through the wireless connection as the quadcopter maintains flight. All of the maneuvering and stability management is controlled autonomously by onboard computer the quadcopter. The four brushless motors on the quadcopter are controlled in real-time, enabling the quadcopter to maintain a steady hover without vibrating or spinning and to be able to navigate to its destination. The quadcopter uses 3-axis magnetometer, gyroscope, and accelerometer, for positional feedback as part of a stabilization algorithm. To send commands to the multicopter the user connect to serial wireless link and send the GPS coordinates and flight parameters to target.

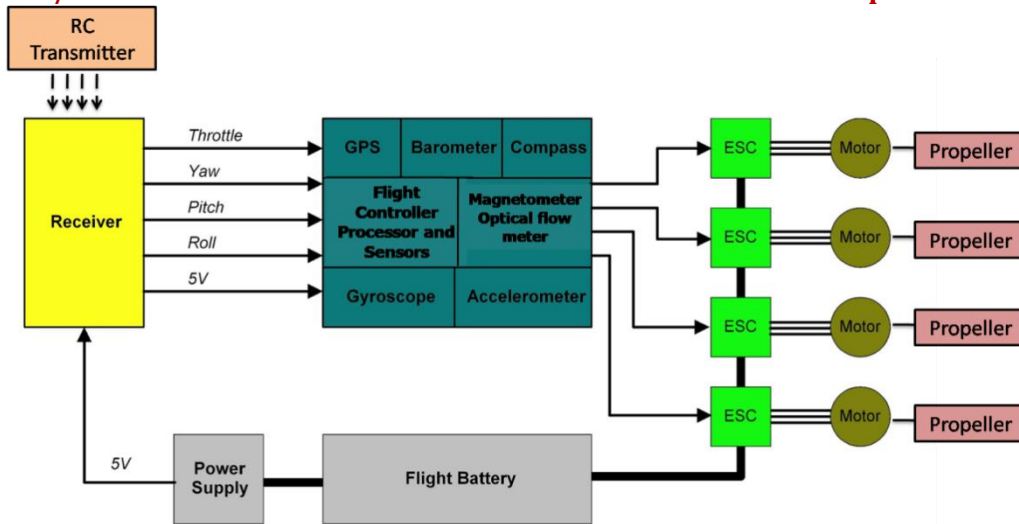

Figure 4.1 Block diagram

Multicopter consists of four or eight rotor/propeller attached to each motor shaft. Four rotors with fixed angles represent fixed pitch to generate equivalent force at each end to lift the body and payload. All DC brushless motors are attached to electronic speed controller to control speed of each individual motor. Four electronic speed controllers connected with each other by parallel connection in to power distribution board. A battery is used as power source. The rotation of propeller is controlled by remote controller (RC).

Further the power distributes equally to four electronic speed controllers and then goes in to each DC brushless motors. Accelerometers will measure the angle of multicopter's in terms of X, Y and Z axis and accordingly adjust the RPM of each motor in order to self stabilize by it-self. The stability is provided by setting the direction of rotation clockwise of one set of opposite motors and counter-clockwise of other set of motors which nullifies the net moment and gyroscopic effects.

i) Transmitter

A radio transmitter is a device that allows the pilots to control the aircraft wirelessly. The signal/commands are then received by a radio receiver (RX) which is connected to a flight controller. The number of channels determines how many individual aux functions and control that can configure in the TX. For example, throttle, yaw (rotating right and left), pitch (lean forward and backward), and roll (roll left and right), each takes up 1 channel. Four channels are the bare minimum to control a quadcopter (pitch, roll, throttle, yaw). Additional channels on a transmitter are often called AUX channels (Auxiliary), in the form of switches and pots (potentiometer or knob). It can be used to change flight modes or trigger certain function/features on the multicopter. In general it is recommended to have at least 5 or 6 channels for a quadcopter. The extra 1 or 2 channels can be used to arm the uav or switch between different flight modes. Four output channels from the transmitter to control the thrust, rudder, ailerons, and elevators respectively. The thrust channel controls how much uniform power is supplied to all 4 motors and is used to control the altitude of the quad copter (left), and the ailerons channel controls the roll of the quad copter (right). The rudder channel controls the yaw of the quad copter (left), and the elevators channel controls the pitch of the quad copter (right). There are two joysticks in the transmitter. Each joy stick has two potentiometers and each potentiometer has three pins. Upper and lower pins are for supply. A pin in-between these are for signal output voltage that varies from 0V to 3.3V.



Figure 4.2 Transmitter source google

ii) Receiver

The radio receiver (Rx) receives radio signals from an RC transmitter and converts them into control signals for each control channel (throttle, yaw, roll & pitch). Modern RC receivers operate on a 2.4 GHz radio frequency. Rx units may have as few as 4 channels, but many have more channels for additional control options. An RC module can transmit only digital data. This is either on or off. To transmit data of 4 channels PPM based signal are used. Microcontroller in RC transmitter reads values from various pots of remote that are generated by PPM signal as per position of sticks. This generated signal is transmitted by RC transmitter to RC receiver module. As Rx captures PPM signal it decodes it and separates all channel values. This data contains lots of noise that reduced by code.

The RC receiver accepts radio signals from an RC transmitter and translates it into separate channels of control. The receiver in our quadcopter is capable of outputting 6 channels of control, including throttle, yaw, roll, pitch, and 2 auxiliary channels (controlled by toggle switches on the transmitter).



Figure 4.3 Receiver source google

iii) Battery Eliminator Circuit

Most of the time, the electronics (flight controller, receiver, camera etc.) only need a 5V power supply, but the voltage from the LiPo battery is greater than that. Therefore, a voltage regulator/UBEC is needed. BEC stands for battery eliminator circuit, and all it does is eliminate the need for a separate battery to power the electronics. An external BEC or UBEC (universal battery eliminator circuit) of the switching kind is used, since it's much more efficient and more. The benefit of using a power module is that it gives the ability to measure battery voltage and capacity. This is useful because if flight controller can measure the battery it knows when battery is running low so it can warn you to land



Figure 4.4 UBEC



Figure 4.5 Power modules

iv) Sensors

Despite their size, multicopters are outfitted with an array of sensors. The MPU-9250 hosts a three-axis magnetometer, accelerometer, and gyroscope (IMU). Together these offer 9 Degrees of Freedom (DOF). Combined with the pressure sensor this gives us 10DOF.

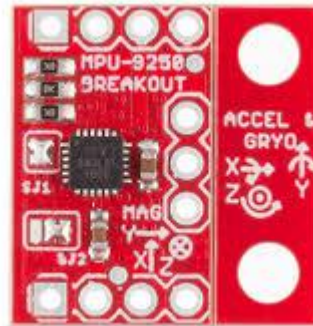

Figure 4.6 MPU-9250 source google

a) *Magnetometer* - Magnetometers measure the magnetic field around them. They are, essentially, a compass. The quadcopter uses this to determine its orientation in space.

b) *Gyroscope* - Gyroscopes measure the **rotational acceleration** of the sensor. They are commonly used in planes to determine the horizon.

c) *Accelerometer* - Accelerometers measure the **lateral acceleration** of the sensor (not rotationally).

d) *GPS* -The information is gathered from satellites and calculated to give the current position of the receiver. Information of position, heading and velocity can easily be calculated and used to verify the current position.



Figure 4.7 GPS source google

e) **Barometer** - A barometer is a pressure sensor that you use to measure the aircraft's altitude. These pressure sensors are so sensitive that they can detect the change in air pressure when your drone moves a few centimeters.

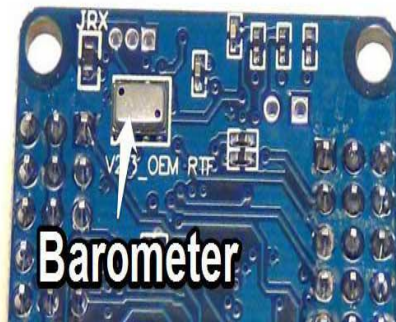

Figure 4.8 Barometer source google

f) **Compass** - The compass sensor, or magnetometer, measures the magnetic force, just like a compass. This sensor is important for multi rotor drones because the accelerometer and gyroscope sensors are not enough to let the flight controller know what direction the drone is facing. Compass sensors are very sensitive to magnetic interference. Things such as wires, motors and ESC's can all cause magnetic interference. so that is why you will often have an additional compass sensor mounted on the GPS module as the GPS module is usually mounted far away from all the other equipment.

g) **Optic flow meter** - An optical flow sensor is a vision sensor capable of measuring optical flow or visual motion and outputting a measurement based on optical flow.

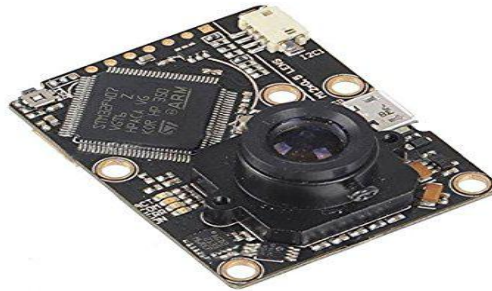

Figure 4.9 Optic flow meter pixhawk

v) Flight Controller Processor

The flight controller is the brain of the quadcopter, and performs the necessary operations to keep the quadcopter stable and controllable. It accepts user control commands from the Rx, combines them with readings from the sensors, and calculates the necessary motor output. For multicopter, there would be a purpose-made flight controller board. The controller takes signals from the channels and transmits the signal to the necessary motors to make the desired action happen. The copter flight would not be very smooth without the use of a microcontroller. The flight controller has fixed channels of throttle, rudder, aileron and elevator. If the throttle is increased all four of the motors speed up at the same rate, if the rudder stick is moved to the left or right either both the clockwise motors or counterclockwise motors speed up to rotate the quadcopter. If the aileron is increased left or right either the left half motors or right half motors speed up to move sideways. If the elevator stick is moved up or down the back two motors or front two motors speed up to move forward or backward. **Processor** is the central unit that runs the quadcopter and performs all the calculations. Main microcontroller is [STM32F427](#) with CPU running at 180MHz, RAM: 256 KB SRAM (L1), Failsafe microcontroller STM32F100 with CPU running at 24 MHz RAM: 8 KB SRAM.

a) Connectivity

- 1x I2C
- 1x CAN (2x optional)
- 1x ADC
- 4x UART (2x with flow control)
- 1x Console
- 8x PWM with manual override
- 6x PWM / GPIO

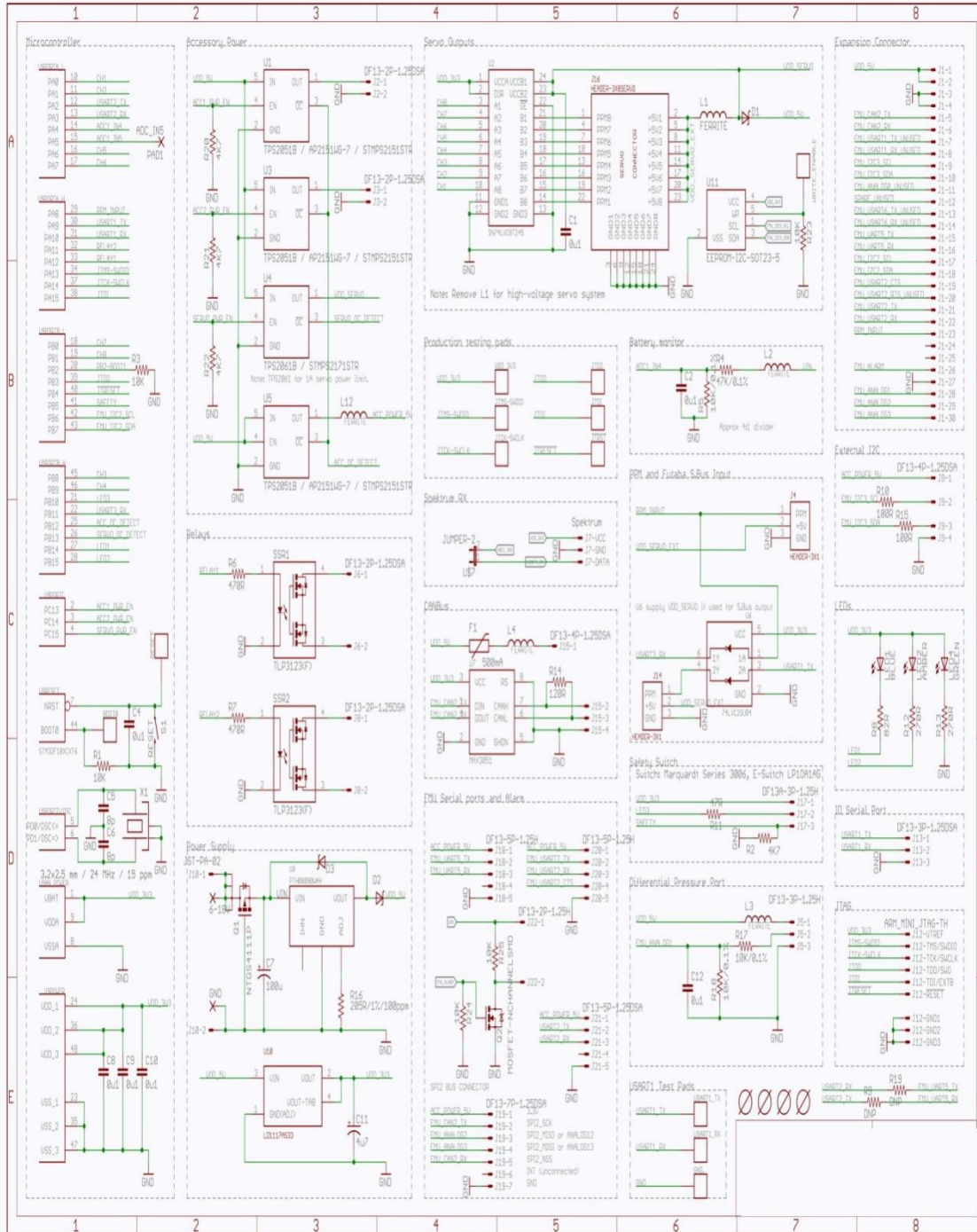

Fig

ure 4.10 Flight controller circuit diagram

vi) Electronic speed control (ESC)

An ESC (Electronic Speed Controller) is what allows the flight controller to control the speed and direction of a motor. ESC is an electronic circuit to vary the speed, direction and possible to act as a dynamic brake, of a brushless Motor. The ESC must be able to handle the maximum current which the motor might consume, and be able to provide it at the right voltage. Electronic speed controllers act as a translator, taking signals from the flight controller, converting these signals to electrical pulses and sending them to the motors. Each motor is connected to an ESC, so the RPM of each motor can vary independently of the other three motors. ESC creates heat in its normal operation; because of this, the body of the ESC is equipped with a heat sink for more efficient heat transfer and cooling. The ESC is also equipped with a brake, which can help the motor stop spinning. The ESCs are connected to the flight control board (FCB), which gets input about how much power is requested from the steering system and outputs signals to the ESCs, which in turn provide the requested power to the motors. The desired thrust should be approximately twice the total weight of the system; this means that the quadcopter could hover at half throttle.

There are a variety of additional features with which an ESC can be equipped. One is a battery eliminator circuit (BEC), which provides power to the receiver without needing additional batteries. Most commonly, this feature is found when using batteries with smaller cell counts, since the BEC converts the battery's output voltage to 5V, which is what the receiver requires. Another feature is motor cut-off, which is often a feature within the BEC feature. Motor cut-off does exactly that; it cuts power to the motor when the battery is low, so the quadcopter can land safely before the battery is depleted. One feature that cannot be paired with a BEC is the opto-isolation feature, which isolates the signal sent to the radio transmitter from the signal received from the ESC; this cuts down on the amount of noise the ESCs receive. One final feature relevant to this discussion is called a brake feature, and again, it does exactly what the name suggests. When the throttle is at zero, it stops the motor from spinning, effectively stopping the momentum caused by the previously spinning propellers.



Figure 4.11 ESC

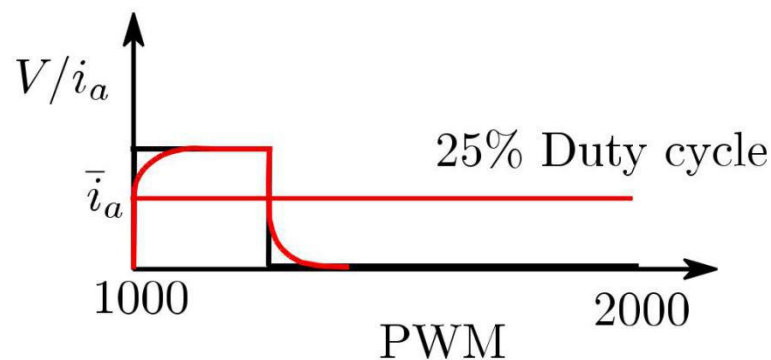

Figure 4.12 Average measured current, phase current and voltage at 20kHz

vii) Motor

Quadrotors do not have swash plate mechanisms, the differential thrust produced by individual rotors is regulated to achieve control of the vehicle. Electric motors operate on Faraday’s law of electromagnetic induction which states that the electromotive force (emf) induced in an inductor coil is directly proportional to the rate of change of the flux linkage. As such, to create an emf, one needs a rotating coil (inductor) in a magnetic field. Faraday’s law lead to the development of the direct current (DC) motor. Stepper, brushed and brushless direct current motors are the most common types of DC motors. The simplest form of DC motors, the brushed DC motor was designed in the late 1800s. As the name implies brushed DC motors operate from a direct current power supply. The most common brushed DC motors consist of an armature or rotor made out of an electromagnetic material, a commutator which provides physical contact to the brushes and a permanent magnet. Unlike brushed DC motors, brushless direct current (BLDC) motors as the name implies do not use brushes. They are also called permanent magnet DC Synchronous motors as the permanent magnets are wrapped around the perimeter of the rotor in a cross pattern. In a brushless DC motor, the winding sits in the stationary part of the motor thus increasing their lifespan compared to brushed motors. Because of their better characteristics and superior performance to brushed DC motors, brushless DC motors have rapidly gained popularity. In addition, brushless DC motors provide feedback on the position of the motor poles and therefore rotational speed of the motor-rotor system. The most common rotor speed sensors used on brushless DC motors are the Hall Effect sensors which give direct measurements of rotor speed. However for small scale quad rotors, indirect methods which rely on the detection of the zero crossings of the motor phases are popular given that no additional sensors are required. Both rotor speed sensing methods ensure that with BLDC motors, precise rotational speed control of the motor is possible. This is why BLDC motors are the most common electric motors in the quadrotor community. However, BLDC motors require complex and expensive electronics known as electronic speed controllers (ESC) that converts the DC voltage into three phase voltages.

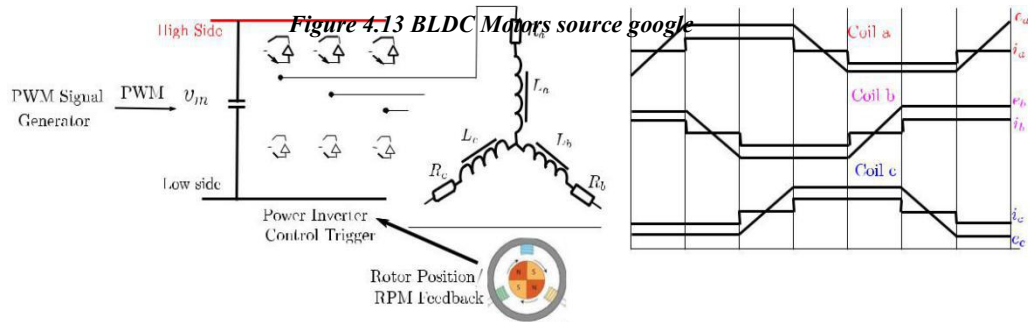
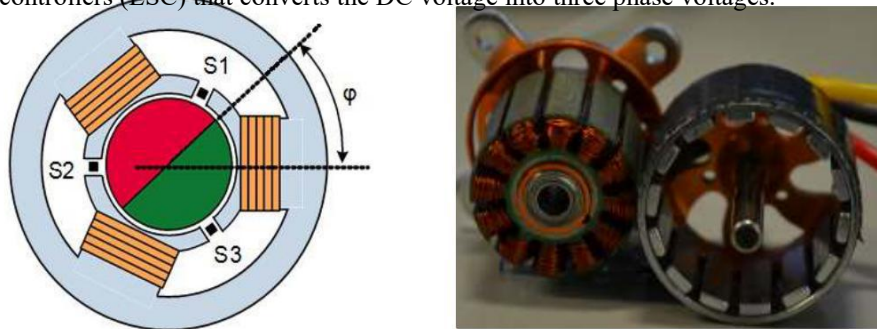

Figure 4.14: BLDC motor and ESC MOSFET drive mechanism.

K_v is the relationship between the rpm and the voltage and is given for most of the BLDC’s.

$$K_v = 922 \frac{rpm}{volt}$$

Brushless motors are used for all quadcopter applications. The torque produced by the electric motors is given by,

$$\tau = K_t (I - I_0)$$

I = Input current,

I_0 = Current when there is no load on the motor

K_t = Torque proportionality constant.

The voltage across the motor is the sum of the back-EMF and some resistive loss.

$$V = IR_m + \omega K_v$$

V = Voltage drop across the motor,

R_m = Motor resistance,

ω = Angular velocity of the motor, and

K_v = Proportionality constant (Back-EMF generated per RPM).

The power motor consumes is,

$$P = IV \\ = K_v * \tau \omega K_t$$



Figure 4.13 BLDC Motors Tmotor

viii) Propellers

The purpose of quad copter propellers is to generate thrust and torque to keep drone flying, and to maneuver. The upward thrust force generated by the propellers is usually measured in pounds or grams. To keep drone flying at a hover, the upward thrust needs to equal the weight of your drone. The thrust to weight ratio TWR (thrust divided by weight), indicates how much thrust your drone generates relative to its weight. Typically, quad copter propellers produce more thrust the faster they spin. The quadcopter propeller pitch is a measurement of how far that a propeller will move through the air for every single rotation of the motor/propeller. The propellers are usually made of carbon fiber

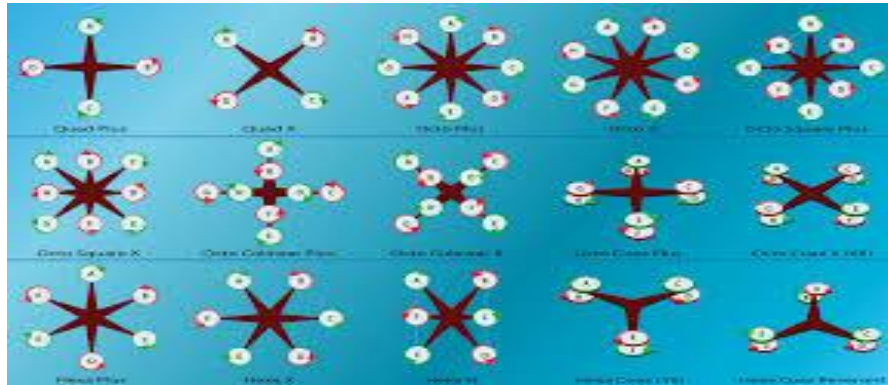

Figure 4.14 Propeller directions



Figure 3.15 Carbon fiber propeller tmotor

ix) Flight Battery

The battery is the powerhouse of the quadcopter. It supplies the motors, the ESCs, the flight controller, and the receiver with power. Due to their lightweight and compact nature, in addition to high discharge rates, lithium-ion polymer (LiPo) batteries are the standard in the aircraft industry. Another specification is the capacity of the battery, measured in milliamp-hours. Finally, there is the C-rating of the battery, which works in conjunction with the capacity to determine the maximum current that can be drawn from the battery before it starts catching on fire, exploding, or being damage. Flight time will be analyzed to determine the appropriate battery. Flight time, which is directly proportional to battery capacity, can be found by dividing battery capacity by the amount of amps being drawn from the battery. Flight time is given by,

$$\text{Flight Time} = \frac{\text{Battery Capacity}}{\text{Amps}}$$

x) DYNAMIC MODEL

When the quadcopter is navigating in three dimensional spaces there are two different coordinate systems present. One is the body coordinate system, indexed 'b', which is affected by the motors. The other is the navigation frame,

indexed 'n', were forces like gravitation has influence. The body coordinate system will move along with the quadcopter, while the navigation coordinate system is the reference point for the quadcopter. The reference coordinate system can be placed anywhere, but has to be fixed once the quadcopter starts moving. One assumption for the coordinate systems is the neglected curvature of the earth. A quadcopter has a limited area to navigate in and this assumption will not affect any result. In avionics the Z-axis is normally pointing towards the earth. The quadcopter is able to rotate around its own axes with an angular velocity. This angular velocity is denoted as $\dot{\sigma}$ with an index for the corresponding axis.

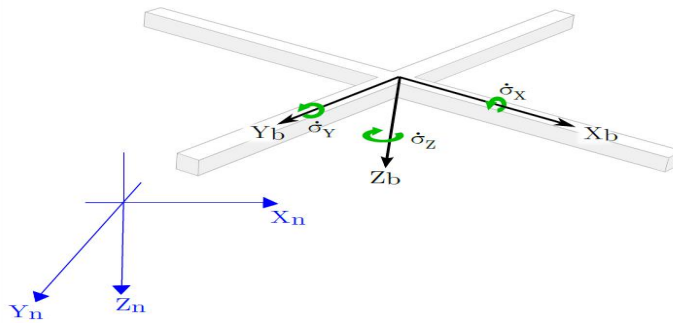

Fig 4.16: The blue coordinates are the navigation frame, while the black is the body coordinates

In order to get the orientation of the quadcopter in terms of angles, the quadcopters coordinate system has to be linked to the navigation coordinates. The way this is done is by the implementation of Euler angles. There are three Euler angles, ϕ , θ and ψ , known as roll, pitch and yaw. This notation is often used in avionics.

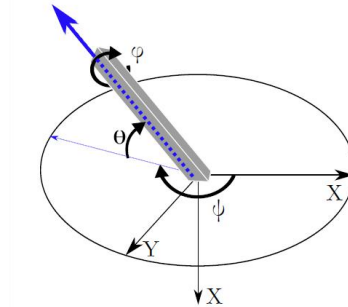

Fig 3.18: Euler angles

- b* - Referred to body frame, onboard.
- n* - Referred to navigation frame, fixed
- σ - General angle
- $\dot{\sigma}$ - General angular velocity
- ϕ - Euler angle for the roll
- θ - Euler angle for the pitch
- ψ - Euler angle for the yaw
- \underline{C}_{u}^v - Transformation matrix from u-frame to v-frame

i) Forces

To start setting up a dynamic model, the most basic thing is to map which forces is acting on the module.

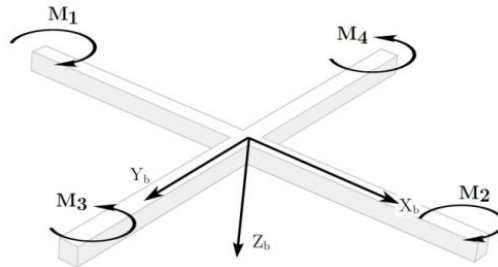

Fig 3.19: Sketch of where the motors are mounted and direction of propeller movement

Each motor have its own force acting in negative direction and also a moment that is acting in the opposite direction of the rotation of the motors. source google

The motors rotation and position is also of significant. Motor one and two are placed along the X-axis and rotate the in the clockwise direction. Motor three and four are placed on the Y-axis and rotate in the counter clockwise direction. Quaternion is not taken into consideration.

a) Mass and Acceleration

Newton first law gives us,

$$\underline{F}_{mass} = m_{total} * \begin{bmatrix} \ddot{X}_b \\ \ddot{Y}_b \\ \ddot{Z}_b \end{bmatrix}$$

b) Gravity

The gravity vector, F_g , is pulling the quadcopter in positive z-direction in the navigation frame. It can be represented in the body frame by multiplying the vector by the transformation matrix:

$$\underline{F}_{gb} = m_{total} \underline{C}_n^b \begin{bmatrix} 0 \\ 0 \\ g \end{bmatrix}$$

$$\underline{F}_{gb} = m_{total} * g * \begin{bmatrix} \sin(\theta) \\ -\sin(\phi) \cdot \cos(\theta) \\ \cos(\phi) \cdot \cos(\theta) \end{bmatrix}$$

c) Propeller Thrust

The force from the propellers are assumed that always will be parallel to the Z-axis in the body frame; hence there will be no force in the X- and Y-direction. This assumption yields only if the propeller is a rigid body with no flapping. In real life this is not the case, but the flapping is neglected from the equation. The generated thrust is a function of the propeller dimensions, and the rpm.

$$\underline{F}_{thrust} = \begin{bmatrix} 0 \\ 0 \\ F_{M1} + F_{M2} + F_{M3} \end{bmatrix}$$

d) Force Drag

As an object moves through the air it will experience drag forces that will work in the opposite direction the object is traveling. This drag force is generated by the friction in the air; this effect has the same properties of a dampening device in a system.

The Drag force is determent by the formula,

$$F_{drag} = \frac{1}{2} \cdot \rho \cdot v^2 \cdot S_w \cdot C_D$$

Where,

ρ = Air density

v = Velocity
 S_w = Reference area
 C_D = Drag coefficient

e) *Disturbance*

Other forces like the Coriolis force from the earth, wind and Euler forces are considered as a disturbance, summarized as $F_{disturbance}$.

f) *Force Equations*

The forces explained earlier are summed together to find the total forces acting on the quadcopter:

$$m_{total} \cdot \ddot{\underline{r}} = \underline{F}_{gravity} - \underline{F}_{thrust} + \underline{F}_{disturbance} + \underline{F}_{drag}$$

$$\ddot{\underline{r}} = \frac{1}{m_{total}} \left(\underline{F}_{gravity} - \underline{F}_{thrust} + \underline{F}_{disturbance} + \underline{F}_{drag} \right)$$

The acceleration of the body frame is converted into navigation frame by using the transformation matrix:

$$\begin{bmatrix} \ddot{X}_n \\ \ddot{Y}_n \\ \ddot{Z}_n \end{bmatrix} = \underline{C}_b^n \begin{bmatrix} \ddot{X}_b \\ \ddot{Y}_b \\ \ddot{Z}_b \end{bmatrix}$$

x) Attitude Estimation

The IMU is strapped down to the quadcopter and measuring acceleration and angular velocity for the body coordinate system on the quadcopter. For a single axis system the attitude can easily be determined by for instance a first order complimentary filter where the gyro is being integrated. But for a multi axis system the attitude cannot be determined that easily because the attitude is dependant of the sequence of the rotation.

Complementary filter is the most common filter used on UAV's. It provides a robust tradeoff between a good short term precision from the gyroscopes and a long term accuracy provided by accelerometers. This complementary filter is also proved asymptotically stable.

xi) Position Estimation

An important feature for an autonomous robot is its ability to know where it is at any time. There are several methods to solve position calculation, ranging from triangulation from known positions in the area to internal navigation system that calculates an approximated position with the help from onboard sensors. GPS is a good method to use while moving outdoors. The information is gathered from satellites and calculated to give the current position of the receiver. Information of position, heading and velocity can easily be calculated and used to verify the robots current position. Multicopter has been fitted with a GPS module Even though the GPS is not used in the control system, a program was made to read the information from the GPS to make sure the module was working properly.

xii) CONTROL SYSTEM

The main purpose of the control system is to control the quadcopter at given Euler angles. A position control will be an improvement but is not implemented. The position controller can calculate different position set points for the angle controller described in this chapter and the total motor thrust, and hence work independent of the angle controller.

a) *Yaw* – This is the rotating or swiveling of the head of the quadcopter either to right or left. It is the basic movement to spin the quadcopter. On most drones, it is the achieved by using the left throttle stick either to the left or right.

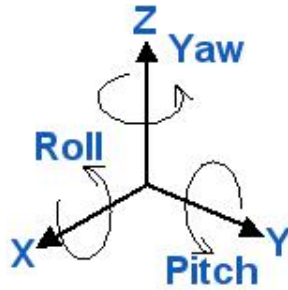

Fig 3.21 Propeller Direction

b) Pitch – This is the movement of quadcopter either forward or backward. Forward Pitch is achieved generally by pushing the throttle stick forward, which makes the quadcopter tilt and move forward, away from you. Backward pitch is achieved by moving the throttle stick backwards.

c) Roll – Most people get confused with Roll and Yaw. Roll is making the quadcopter fly sideways, either to left or right. Roll is controlled by the right throttle stick, making it fly either left of right.

- To pitch forward, the front two propellers (1 & 2) would spin at a slower rate than the back two propellers (3 & 4) would; this can be achieved by decreasing the RPM of the front two propellers and/or increasing the RPM of the back two propellers.
- To pitch backward, the front two propellers would spin at a faster rate than the back two propellers. To roll to the right, the left two propellers (1 & 4) would spin at a faster rate than the right two propellers (2 & 3) would; again, this would be achieved by increasing the RPM of the left two propellers and/or decreasing the RPM of the right two propellers.

Xiii) Flight Control Board

The FC flight management unit the FC input/output (FCIO) are the primary avionics boards used on the quadrotor platforms developed. An STM32F405RGT6 microcontroller unit (MCU) which has a 168MHz Cortex M4F CPU with 198KB RAM and 1MB of flash. The FCIO is the main in-put/output board of the IO avionics stack. The FCIO has a 24MHz Cor-tex M3 fail-safe controller with 8 PWM (pulse width modulation) servo outputs that operate between 50 and 400Hz, a Futaba S.Bus compatible receiver and a CPPM (combined pulse position modulation) pins. The board has 4 UARTs (universal asyn-chronous receiver/transmitter), 2 I2Cs (inter-integrated circuit), 1 SPI (serial periph-eral interface), 1 CAN (controller area network) interface and up to 8 GPIO (general-purpose input/output) pins. The IO board also has a 1-18V battery voltage sensor and regulator with a reverse polarity protection unit. It should be noted that despite the FCIO boards being the primary avionics boards, the Pixhawk which combines the FMU and IO boards into a single board is also used. The 20 to 400Hz PWM signal generation imply they can work with a wide variety of electronic speed con-trollers. The many UART pins imply that multiple peripherals can be used though the low computational memory indicates the need for computationally efficient algorithms.

Table 3.1: Available sensors.

Sensors	MS5611-01BA03	HMC5883L	MPU6000
Measurements	barometric pres- sure	Earth's magnetic field (Magnetome- ter)	Linear accelera- tion and angular velocity (IMU)
Range	1kPa to 120kPa	8G	2, 4, 8, 16g and 250, 500, 1000, 2000 /s
Resolution/ Accu-	1.2Pa	10mG	

racy			
Rate	160	160	1kHz
Communication	I2C, SPI	I2C, SPI	SPI
Temperature Range	40 to +85 C	40 to +85 C	40 to +85 C

XIV) Sensors

The FC has an Invensense MPU6000 inertial measurement unit (IMU) which has a 3-axis accelerometer and a 3-axis gyroscope for measuring linear accelerations and angular velocities respectively. The MPU6000 communicates with the microcontroller unit (MCU) via SPI at a maximum rate of 1kHz (to be precise, 200Hz due to thread priorities and scheduling). The FCFMU also has an MEAS MS5611 barometric pressure sensor that can communicate with the MCU via I2C or SPI at the rate of 160Hz. The MS5611 pressure sensor measurements change under the influence of the lighting condition and are very sensitive to aerodynamic changes. This measured barometric pressure is then converted to altitude based on the mean sea level (MSL). The FC also has the Honeywell HMC5883L magnetometer. This sensor is a surface mounted multi-chip module that measures the magnetic field of the earth. It communicates at 160Hz to the MCU via I2C. It is used only in the attitude filter to determine the heading angle or the vehicle's orientation in $\sim e_1$ with respect to the magnetic north pole. In addition to the aforementioned sensors, Pixhawk has an STML3GD20H gyroscope and an STMLSM303D accelerometer and magnetometer as redundant sensors. Both the FCFMU and Pixhawk use a Micro-SD card for storage of the flight data and commands for applications that should be run.

i) Input output interface/hardware communication

As seen in the various components that constitute the quadrotor platforms developed, electronic speed controllers (ESCs) communicate with the avionics board via I2C (specifically I2C3). The four ESCs with addresses 1 to 4 act as slaves to the avionics board which acts as master. The FC sends a thrust commands at 50Hz as 8 or 11bit integer values to be regulated by the ESCs. The ESCs then do the thrust regulation and send back 2 16bit integers (filtered current and rotor speed) to the FC master.

ii) Voltage and rotor speed sensors

As pointed out in Section 2.4.4, the RPM sensor on ESC32v2 is based on the back-emf zero-crossing detection whereas the voltage uses a voltage divider circuit. All measurements on the ESC are stored as 2 or 4 16bit floating-point numbers saved on the ADC SQR registers and the DMA controller transfers the stored data from registers to local variables.

iii) RPM sensing

If n is the number of poles and F is the run RPM factor and n is the period of the ADC crossings during the zero-crossing detection, then the measured rotor speed.

iv) Voltage sensing

The STM32F103103CB microcontroller unit (MCU) uses a reference voltage of $v_{ref} = 3.3V$. Given that in the voltage divider sub-circuit for voltage sensing, the resistors are $R_{top} = 10K$, $R_{bot} = 1.5K$, then the resulting voltage scaling R_{VD} is

$$R_{VD} = \frac{10.0 + 1.5}{1.5}$$

Multiplying this by the MCU’s reference voltage v_{ref} yields the ADC scaling voltage

$$v_{ADC} = v_{ref} R_{VD}$$

If the ADC voltage measurement in the DMA is v_{DMA} , then the measured bus voltage is

$$V = v_{DMA} v_{ADC}$$

This measured voltage is used without any filtering throughout especially in determining the voltage across the motor and the implementation of duty cycle.

v) Current sensing

Current sensing is one of the main stand outs of ESC32v2. The current sensing computation uses a 16bit ADC precision and a circuit with a high amplification gain of $K_{R_s} = 50.9$. If the measured current in the ADC register is \bar{I} and \bar{I}_{offset} is the measurement offset, then the measured current \bar{i}_a is given by

$$K_{I_{ADC}} = \frac{\frac{v_{ref}}{2^2} \cdot 8}{\frac{R_s}{1000}},$$

where $R_s = 1000^{0.5} \text{ W}$ is the shunt resistance. Thus the ADC to amps gain is $K_{I_{ADC}} = 483.03616 \cdot 10^9$. It is a constant for all the ESCs. Clearly this is not true and as such

vi) Current calibration

It is very important for the aerodynamic mechanical power model presented in the later chapters of this thesis that at the same static condition, the same current is measured for the same RPM. This is a challenge given the low tolerance and poor qualities of the components used on the ESC. As has been stated, current sensing on the ESC is designed for overcurrent protection

1. Temperature causing the resistance of the shunt resistor and other resistive components on the ESC circuit board to change.
2. High noise characteristics in the measurements resulting in variations in \bar{I}_{offset} for an ESC.
3. Effect of the assumed constant ADC to amps gain $K_{I_{ADC}}$ given the low tolerance of electrical components.

To investigate the effect of temperature, an external ammeter was attached to the cable around the ESC powered from a constant voltage power source at 16.4V while the duty cycle is set to a constant value. The temperature effect on v_{ref} is captured by analysing the MCU temperature variation with measured current at a constant motor voltage. First, two sets of experiments (red and blue lines) were performed to see the effect of the MCU temperature on the current offset which is one of the factors that affects the constant current measurement for the same constant RPM and voltage in static free air. In each of these experiments, there were 10 sub experiments in which the ESC is stopped and started. When the ESC is stopped, the MCU temperature is taken using an infrared camera. The offset is read when the motor is just about to start which is seen in the constant offset lines per experiment. Though the two experiments show similar responses in MCU temperature and offset values, Figure 3.4 shows no observable relationship between the two variables. Furthermore, the same temperature variation was observed for each of the components on the printed circuit board (PCB) especially the shunt resistor.

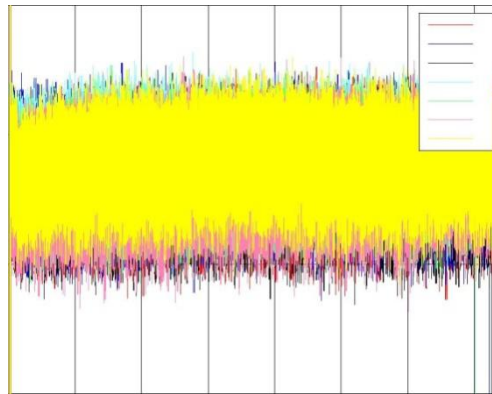
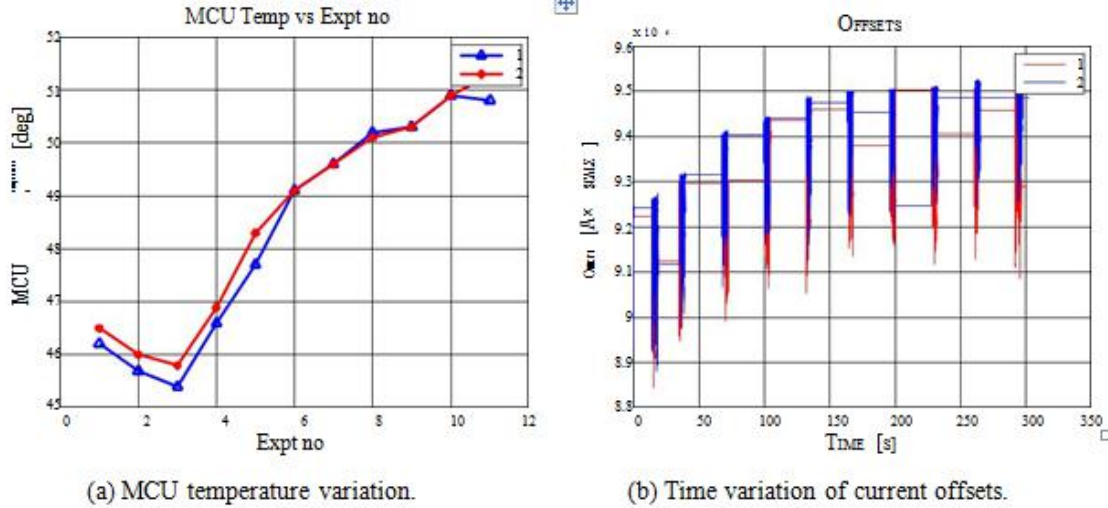

Figure 3.5: Current measurements

V. MAJOR CONTRIBUTIONS

5.1 Land surveying

The use of Unmanned Aerial Vehicles (UAVs) for surveying is now widespread and operational for several applications – quarry monitoring, archeological site surveys, forest management and 3D modeling for buildings, for instance. UAV is increasingly used by land surveyors especially for those kinds of projects. It is still ambiguous whether UAV can be applicable for smaller sites and property division. Therefore, the objective of this research is to extract a vectorized plan utilizing a UAV for a small site and investigate the possibility of an official land surveyor exploiting and certificating it. To do that, two plans were created, one using a UAV and another utilizing classical land surveyor instruments (Total Station). A comparison was conducted between the two plans to evaluate the accuracy of the UAV technique compared to the classical one. Moreover, other parameters were also considered such as execution time and the surface covered. The main problems associated with using a UAV are the level of precision and the visualization of the whole area. The results indicated that the precision is quite satisfactory with a maximum error of 1.0 cm on ground control points, and 4 cm for the rest of the model. On the other hand, the results showed that it is not possible to represent the whole area of interest utilizing a UAV, due to vegetation. Land surveying is one of the oldest professions on earth. The purpose of many surveys nowadays is to create a 2D plan that a land surveyor and his client could use to obtain a building permit. Innovation in topography and land surveying is aimed at acquiring more data with higher accuracy. Computer developments were a key change in that regard. Nowadays, utilizing drones could lead to another quantum leap in the surveying profession. With the

development of smart cities and BIM technologies, it will probably become easy to create a 3D model of a terrain utilizing UAVs and exporting it to a 3D Geographic Information System (GIS). Up until now, for construction sites, 2D plans have been required to get reliable measurements quickly. Topographic plans are widely used in a variety of applications and at various sites. These plans involve several levels of accuracy depending on the client's needs. Usually, projects that require crucial safety conditioning for construction, such as high-speed railways, landing strips, investigating building deformations or tunnel inspections, require plans with high accuracy, where just a few millimeters (mm) of deformation are highly significant. In some countries land surveyors' signature has a legal value. Their tasks involve ensuring the accuracy of a plan and making sure that the landmarks are assigned to the right place. Actually, they use topographic instruments in order to realize the plans. This involves a broad number of applications from private properties to major public infrastructures, roads and network management, for instance. For many topographical surveys, the data are acquired with a total station. A total station is surveying equipment that consists of an electromagnetic measuring instrument and electronic theodolite. It is also integrated with a microprocessor, electronic data collector and storage system. The instrument can be used to measure horizontal and vertical angles as well as the slope distance from the object to the instrument. The redundant measures with total stations allow accuracy to within millimeters to be achieved. Furthermore, their automatic operation enables more data to be acquired in a limited period of time. Over one day a land surveyor can acquire up to 2,000 points. Since the process is repetitive it can easily involve errors. Therefore several techniques can be adopted to avoid, or at least minimize, these possible errors. For instance, the French government set specific legislation on precision classes for topographical surveys in order to control the quality of the data. The survey then has to be georeferenced using different techniques based on the nature of the terrain and the available instruments. Usually, the most efficient technique used is a global navigation satellite system (GNSS) receiver with a real-time kinematic (RTK) network. This allows control points to be obtained with a precision of about 2.0 cm. Once the field survey is completed, the data are transferred to CAD software to generate the plan. Even though codification in the field enables automatic drawing, it usually involves some errors, and the post-treatment process usually takes several hours to obtain the final product. The land property is registered in a document called a "cadastre" (land register). This was first established in the 19th century in the reign of Napoleon. The evolution of topographic instruments and progress in terms of precision revealed that most of the register was inaccurate. Therefore an operation called "bornage" was established to set property boundaries. The goal is to implant the landmarks to set a property's limits. During a "bornage," land surveyors work as a legal expert to delimitate the boundaries between neighbors. The "bornage" encompasses several operations: (i) creation of a "plan de bornage" (this comprises a topographical plan of the state of the property and the projected boundaries); (ii) the acceptance of the plan by the mayor and neighbors; (iii) the projection of the boundaries and generation of a topographical plan of the property after the projection. Various studies have been conducted on using UAV images and photogrammetry for cadastral surveys over large areas and with a precision of 5–10 cm. The effectiveness of UAV for land monitoring in order to analyze and detect disaster areas. They evaluated the accuracy of the digital maps generated from UAV images. They found that the mean error, if only GPS/INS data used, is about 10 m, whereas if ground control point (GCP) used, the mean error is about 10 cm reviewed a theoretical development of UAV in several implementations fields. They recapped the common problems associated with UAV remote sensing. They also provided information on the orientations of future research about it. Rui-sheng et al. 2006 suggested a new methodology of utilizing UAV images to enhance government decision making related to the land use survey. They found that the implementation of UAV image in land use survey is viable, low-cost and promising. Proposed characteristics of small UAV to be suitable for management and research tools. The framework allows for geo-referencing of UAV imagery based on GPS measurements and ground control points (GCPs). The framework also allows for developing enrich 3D models. The micro UAVs with light weight are much flexible and weather independent compared to standard ones. They are useful for forestry and agricultural applications. This can be attributed to the manufacturers of UAVs whom are not aware and familiar with the spatial needs of photogrammetry and GIS data acquirement. The aim of this study is to evaluate the potential of UAVs for much smaller areas and with the best precision possible.

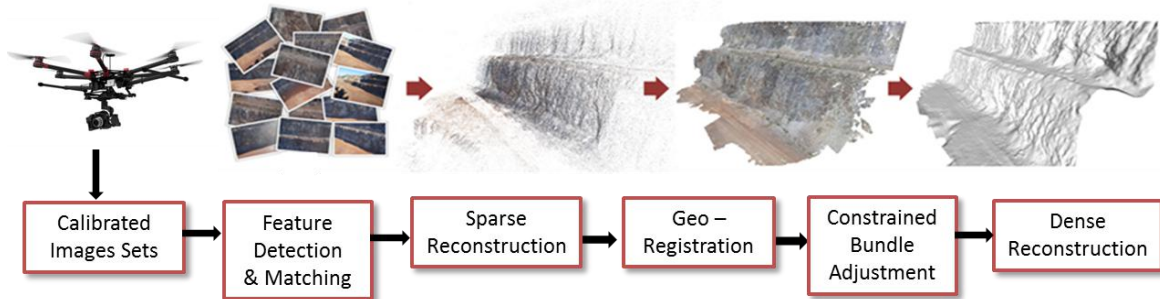

Figure 5.1.1 Work flow

The cameras that were utilized with each UAV were a Canon S110 . CMOS Sensor Effective number of pixels About 12.1 megapixels 16.05 megapixels Focal length 5.2 to 26 mm (equivalent 24 x 36: 24 to 120 mm) 12 mm Maximal opening f/5.9 f/2 ISO sensitivity 80–12,800 100–25,600 Shutter speed 15–1/2000 s 60 min–1/16,000 s GPS recording, Weight 198 gm .A typical image-based aerial surveying with an UAV platform requires a flight or mission planning and GCPs (Ground Control Points) measurement for geo-referencing purposes. After the acquisitions, images can be used for stitching and mosaicking purposes, or they can be the input of the photogrammetric process. In this case, camera calibration and image triangulation are initially performed, in order to generate successively a Digital Surface Model (DSM) or Digital Terrain Model (DTM). A Structure from Motion(SfM) algorithm is implemented to get parameters of camera orientations and to generate a sparse point cloud representation of objects in photos. A patch based multi view stereo algorithm is applied to generate a dense point cloud. Ground control points are used to georeference the data. These products can be finally used for the production of ortho-images, 3D modeling applications or for the extraction of further metric information. Unmanned Aerial Vehicles (UAV) as a data acquisition platform and as a measurement instrument has become attractive for many surveying applications. The mission (flight and data acquisition) is planned, starting from the area of interest, the required ground sample distance (GSD) or footprint, and knowing the intrinsic parameters of the mounted digital camera. Thus fixing the image scale and camera focal length, the flying height is derived. The camera perspective centers (waypoints) are computed fixing the longitudinal and transversal overlap of images. The take-off and landing operations are strictly related to the employed vehicle and characteristics, but normally controlled from ground by a pilot (e.g. with a remote controller). During flight, the platform is normally observed with a control station which shows real-time flight data such as position, speed, attitude and distances, GNSS observations, battery or fuel status, rotor speed, etc. In this system, it carries a camera with a 24.3 megapixel sensor and a modified camera lens with a focal distance of 30 mm .Resolution in aerial photography is measured as ground sampling distance (GSD), the length on the ground corresponding to the side of one pixel in the image, or the distance between pixel centers measured on the ground. The resolution, pixel size or GSD is the size of the projected pixel on the ground. It is directly dependent on the sensor's size and height of flight. As far the terrain is not entirely flat, thus this value is an average of the different pixel size in the model. For instance, a GSD of 1.0 cm means that the pixels on the image represent 1.0 x1.0 cm on the ground. The resolution will dictate what is possible to achieve.

$$GSD = \frac{(Pixel\ Size) \times (Height\ above\ Ground\ Level)}{Focal\ Length}$$

A larger GSD means that fewer details will be resolvable in the image and it will be of lower quality, while a smaller GSD means the exact opposite. GSD goes up as the drone flies higher and goes down as the drone flies lower. GSD is also affected by the camera's focal length, as well as its pixel size. From this ground coverage calculation, it is able to work out how many flight paths will be needed to cover the area the user wants to map with the given camera, and will determine the spacing needed between these flight lines to ensure adequate overlap. Then determines the minimum number of images needed to adequately cover this area, as well as the most suitable flight altitude to ensure adequate coverage as well as a sharp ground resolution. source google

ii) Calibrated Image Sets

A UAV is used to record overlapping aerial images of the test site area. Imagery acquired for photogrammetric processing is flown with two types of overlap: Forward Lap and Side Lap.

Forward lap, which is also called end lap or in-track overlap, to describe the amount of image overlap intentionally introduced between successive photos along a flight line. This type of overlap is used to form stereo-pairs for stereo viewing and processing. The forward lap is measured as a percentage of the total image coverage. Typical value for the forward lap for photogrammetric work is 60-75%. Side lap is the amount of overlap between images from adjacent flight lines.

$$\text{distance between flight lines (SP)} = \frac{\text{Image coverage (W)} \times (100 - \text{Amount of side lap})}{100} \tag{1}$$

$$\text{Number of flight lines (NFL)} = \frac{\text{Width}}{\text{SP}} + 1 \tag{2}$$

$$= \frac{\text{Length}}{\text{Distance between two consecutive images}} + 1 \tag{3}$$

$$\text{Total number of images for the project} = \text{NFL} \times \text{NIM} \tag{4}$$

This type of overlap is needed to make sure that there are no gaps in the coverage. The side lap is measured as a percentage of the total image coverage. Typical value for the side lap for photogrammetric work is 30-60%. The recommend the amount of forward lap is at least 70% and side lap is at least 60%.

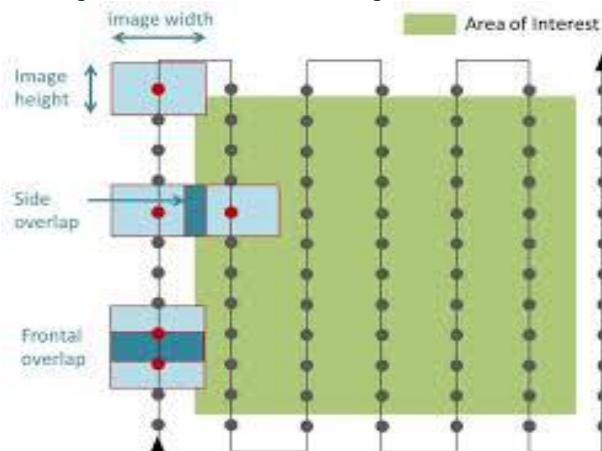

Figure 5.1.2 Flight Path of UAV

Photos taken from these two different angles can be combined in photogrammetry, creating imagery that gives users the ability to view and manipulate multiple perspectives in a single computer-generated model. Photogrammetry is the science of calculating measurements from photos. UAV flight paths or mapping projects should be designed to ensure a sufficient amount of both forward and lateral photographic overlap, which will better allow post processing software to identify common points between each image.

iii) Feature Detection & Matching

Scale Invariant Feature Transform (SIFT) algorithm is normally used for both feature extraction and feature matching. Laplacian operator is used to sharpen depth image, then SIFT algorithm is adopted to get the key points. An algorithm called RANSAC (Random Sample Consensus) is employed as the filter before feature matching.

It can efficiently remove non-related matching points, and thus improve the matching accuracy. SIFT algorithm relatively consumes computational time particularly in the feature matching process because each feature in an image of interest is compared with all features in the subsequent image in order to find the best matched pair.

a) *Feature Detection*

Feature Detection is the process identifying points of interest, also called features or keypoints. Lowe presented the scale-invariant feature transform (SIFT) algorithm, where a number of interest points are detected in the image using the Difference-of-Gaussian (DOG) operator.

The points are selected as local extrema of the DoG function. At each interest point, a feature vector is extracted. Over a number of scales and over a neighborhood around the point of interest, the local orientation of the image is estimated using the local image properties to provide invariance against rotation. Next, a descriptor is computed for each detected point, based on local image information at the characteristic scale. The SIFT descriptor builds a histogram of gradient orientations of sample points in a region around the keypoint, finds the highest orientation value and any other values that are within 80% of the highest, and uses these orientations as the dominant orientation of the keypoint.

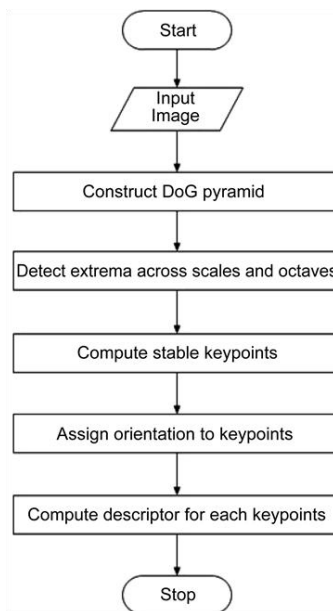

Fig 3: SIFT Algorithm

The keypoints are identified in the images and descriptors are computed. These are then matched between all the images in the set. False matches are removed with the help of determination of fundamental matrix for each of image pairs. In SIFT algorithm, a feature point from one image is chosen, and then another two feature points are found by traversing all the feature points in another corresponding image which have the shortest and next-shortest Euclidean distances. By epipolar geometry, traverse those feature points along the epipolar lines and compute the distance from matching points to the epipolar line. If the value is less than a threshold value, consider it as a matching point. The set of features defined by SIFT can contain outliers or points not common to both images. The computational expense of comparing every feature in an image increases exponentially, as the number of points increases.

b) *Feature Matching*

Feature matching is the process of finding the corresponding keypoint of one image in the other image. After the SIFT feature vectors of the key points are created, the Euclidean distances between the feature vectors are exploited to measure the similarity of key points in different digital images. A feature point from one image is chosen, and then another two feature points are found by traversing all the feature points in another corresponding image which have the shortest and next-shortest Euclidean distances. Among these two feature points, if the divisor between the

shortest and next-shortest noise from outliers cannot be handled with simplistic data fitting models such as the method of least squares, which minimizes the sum of squared distances between an observed point and the fitted value provided by the model. RANSAC (Random Sample Consensus) is an iterative method that is used to estimate parameters of a mathematical model from a set of data containing outliers. Instead, RANSAC, a robust iterative technique that constructs an alignment model in linear time, is used. The RANSAC algorithm assumes that all of the data we are looking at is comprised of both inliers and outliers. Inliers can be explained by a model with a particular set of parameter values, while outliers do not fit that model in any circumstance. The algorithm samples enough points to minimally fit the model and measures the number of inliers and outliers within a given threshold. The process is repeated a set number of times to build a model. The approach is probabilistic and it is robust against noise, although the computation time increases linearly when aligning images. RANSAC generates an inlier count for each image comparison. Fitting a line to a set of points, whereas the model required for SfM matching requires RANSAC to construct an eight-point alignment model in linear time. The greater number of inliers is indicative of a more accurate match. This measure is normally used when comparing how well a feature detector performs.

c) Sparse Reconstruction

Sparse cloud identifies features, or recognizable patterns among pixels and match features between images. Triangulate points to represent those matches as X, Y, Z coordinates with pixel colours assigned to the points. This results in a sparse point cloud that represents the geometry among the images. Depending on the success of the photographic strategy, optimize the model/cloud geometry. Optimization has the potential to bring accuracy to 0.1. The better the photographic strategy for a project, the more efficient these steps are likely to be. The process of inferring sparse 3D structure of a static scene from a moving camera is usually termed as (Scene) Structure from (Camera) Motion (SfM).

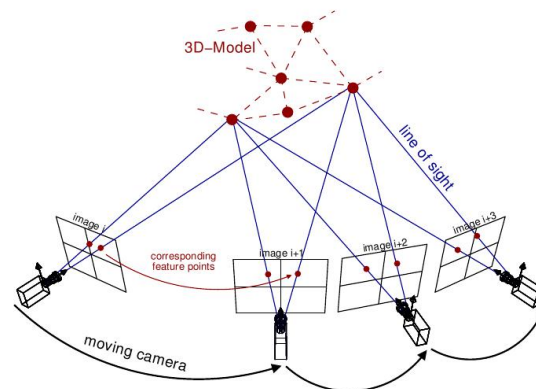

Fig 5: Triangulation Technique

Structure from Motion (SfM), which start by taking two or more photographs, then find correspondences between the images, and finally uses triangulation to obtain 3-d locations of the points. 3D reconstruction from multiple images is the creation of three-dimensional models from a set of images. SfM from multiple views requires point correspondences across multiple images, called tracks. A typical approach is to compute the tracks from pair wise point correspondences. Each track corresponds to a 3-D point in the scene. To compute 3-D points from the tracks, triangulation method is used. work with, as they can be overlaid on existing coordinates in software.

To carry out the process of geo-referencing, the image processing software has to know the real-world GPS coordinates of a small number of visibly identifiable locations in the collected aerial imagery. These coordinates are referred to as ground control points in the UAV mapping context. Some maps must be accurately geo-referenced using GPS technology, permitting them to be used as an accurate overlay and in mapping applications like Google Maps. Geo-referenced point clouds are models of reality, related to a specific place as given by their coordinates and the specification of the used coordinate system in which the realization of a reference system through fixed points is explained. Point clouds cannot only be used to visualize a scene, but also to infer quantitative information. As an

example, distances between identified points can be measured to obtain the height of an underpass, or to measure the length of a fault line.

The 3D point corresponding to a specific image point is constrained to be on the line of sight. From a single image, it is impossible to determine which point on this line corresponds to the image point. If two images are available, then the position of a 3D point can be found as the intersection of the two projection rays. This process is referred to as triangulation. The key for this process is the relations between multiple views which convey the information that corresponding sets of points must contain some structure and that this structure is related to the poses and the calibration of the camera. The final result of this process provides with a series of 3D points or just a point cloud.

v) Geo – Registration

Geo-referencing is the process of assigning spatial coordinates to data that is spatial in nature, but has no explicit geographic coordinate system. Point clouds used in geometric modeling are often acquired by active triangulation. UAV maps are much easier to work with, as they can be overlaid on existing coordinates in software. To carry out the process of geo-referencing, the image processing software has to know the real-world GPS coordinates of a small number of visibly identifiable locations in the collected aerial imagery. These coordinates are referred to as ground control points in the UAV mapping context. Some maps must be accurately geo-referenced using GPS technology, permitting them to be used as an accurate overlay and in mapping applications like Google Maps. Geo-referenced point clouds are models of reality, related to a specific place as given by their coordinates and the specification of the used coordinate system in which the realization of a reference system through fixed points is explained. Point clouds cannot only be used to visualize a scene, but also to infer quantitative information. As an example, distances between identified points can be measured to obtain the height of an underpass, or to measure the length of a fault line.

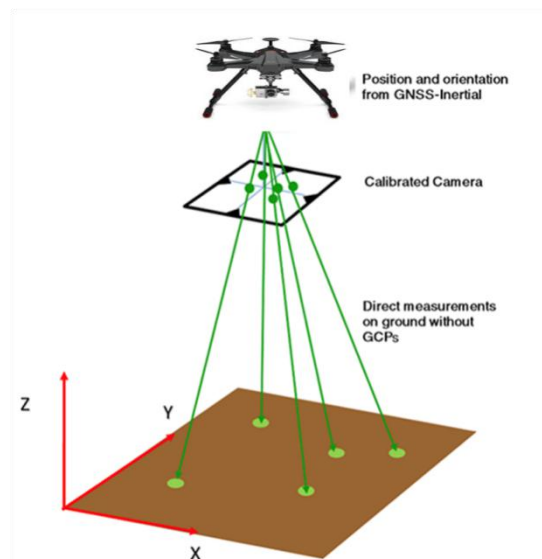

Fig 6: Direct Geo-Referencing source google

Direct Geo-referencing is the direct measurement of the position and orientation of an airborne mapping sensor such as a camera or laser scanner so that each pixel or range can be geo-referenced to the Earth without the need for ground information collected in the field. This is achieved using data collected from Global Navigation Satellite Systems (GNSS) integrated with measurements from inertial sensors that directly attached to the mapping sensor. The data collected from the airborne GNSS and inertial sensors are processed in real-time and in post-mission along with data collected from a single or network of GNSS reference stations to produce



Fig 7: Effect of Bundle Adjustment (Right) source google precise measurements of the sensor position and orientation exactly at the time of exposure or scan.

vi) Constrained Bundle Adjustment

Bundle Adjustment is a technique for simultaneously refining the 3D structures and camera parameters. It is capable of obtaining an optimal reconstruction under certain assumptions on image error models. Bundle adjustment is performed, taking advantage of the sparse Levenberg-Marquardt algorithm. Results of the sparse Levenberg-Marquardt algorithm are parameters of inner and outer camera orientations and a sparse point cloud of 3D tie points. Sparse point cloud is then densified following a multi-view stereo approach.

Bundle adjustment amounts to jointly refining a set of initial camera and structure parameter estimates for finding the set of parameters that most accurately predict the locations of the observed points in the set of available images. More formally, assume that n 3D points are seen in m views and let x_{ij} be the projection of the i^{th} point on image j . Let v_{ij} denote the binary variables that equal 1 if point i is visible in image j and 0 otherwise. Assume also that each camera j is parameterized by a vector a_j and each 3D point i by a vector b_i . Bundle adjustment minimizes the total reprojection error with respect to all 3D point and camera parameters, specifically

$$\min_{\mathbf{a}_j, \mathbf{b}_i} \sum_{i=1}^n \sum_{j=1}^m v_{ij} d(\mathbf{Q}(\mathbf{a}_j, \mathbf{b}_i), \mathbf{x}_{ij})^2$$

where, $\mathbf{Q}(\mathbf{a}_j, \mathbf{b}_i)$ is the predicted projection of point i on image j and $d(x, y)$ denotes the Euclidean distance between the image points represented by vectors x and y . Clearly, bundle adjustment is by definition tolerant to missing image projections and minimizes a physically meaningful criterion. Pure image-based approaches suffer from systematic errors, especially for a few datasets showing long elongated, large-scale. Bundle adjustment refines a visual reconstruction to jointly produce the optimal 3-D structure and the viewing parameters. The bundle refers to the bundle of light rays leaving each 3-D feature and converging on each camera center, as shown in Figure 7. Observed camera block deformations are very often caused by incorrectly estimated radial distortion parameters of the camera.

As a consequence the re-projections of 3D points onto the image plane are not correct and thus cause wrong error measures in the bundle adjustment process. The bundles are optimally adjusted with respect to both feature and camera positions. Bundle adjustment must occur after outlier removal, as the process is sensitive to noise. Bundle adjustment treats the reconstruction as an optimization problem that aims to minimize the re-projection error between noisy images. The viewing parameters and 3D reconstruction parameters are considered equivalent and solved simultaneously. Furthermore, the re-projection error as the sole evaluated error measure has impact on many independent parameters, 3D positions of the object points as well as intrinsic and extrinsic camera parameters. Errors can be passed back and forth during the optimization and camera positions may undergo large changes. These systematic errors causing a deformation of the image block can be avoided by adding external constraints in the bundle adjustment.

vii) Dense Reconstruction

Dense image matching algorithm is used to extract dense point clouds to define the object's surface and its main geometric discontinuities. The derived unstructured point clouds need to be structured and interpolated, maybe simplified and finally textured for photo-realistic visualization. Dense point clouds are generally preferred for

terrain/surface. For the creation of orthoimages, a dense point cloud is mandatory in order to achieve precise ortho-rectification and for a complete removal of terrain distortions.

The sparse point cloud model generated from SfM can be thickened by interpolation. The technique called multi view stereopsis (MVS), which use points that have already been matched and interpolates points using sparse reconstruction.

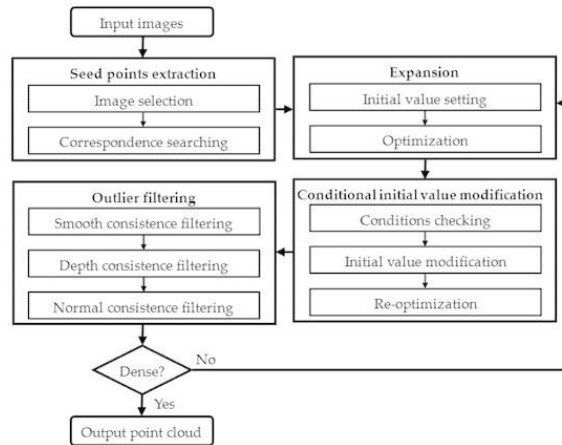

Fig 8: Dense Reconstruction Algorithm

As shown in Fig 8, initially, sparse initial seed points are extracted from input images through a process of image selection, followed by a correspondence-search along epipolar lines. The new points are expanded on the basis of the initial positions and normals set from the seed points, and optimized for a potential increase in accuracy. The expanded points are modified and re-optimized on the condition that their neighbor points are sufficiently dense and centered on them. Once a point has been successfully modified and re-optimized, it will not be modified again. The outliers are deleted via consistency filtering with regard to smoothness, depth and normal. The successfully-expanded points are then used as new seeds and the last three key steps loop again and again until the final 3D point cloud becomes dense enough.

Results and disussion

i) Summary from pix4dmapper

Average GSD	3.39 cm/ 1.33 in
Area Covered	0.1341 km ² /13.4111 ha/ 0.0518sq.mi/ 33.1566 acres

ii) Quality Check

Images	Median of 42864 keypoints per image
Dataset	261out of 261 images calibrated(100%), all images enabled

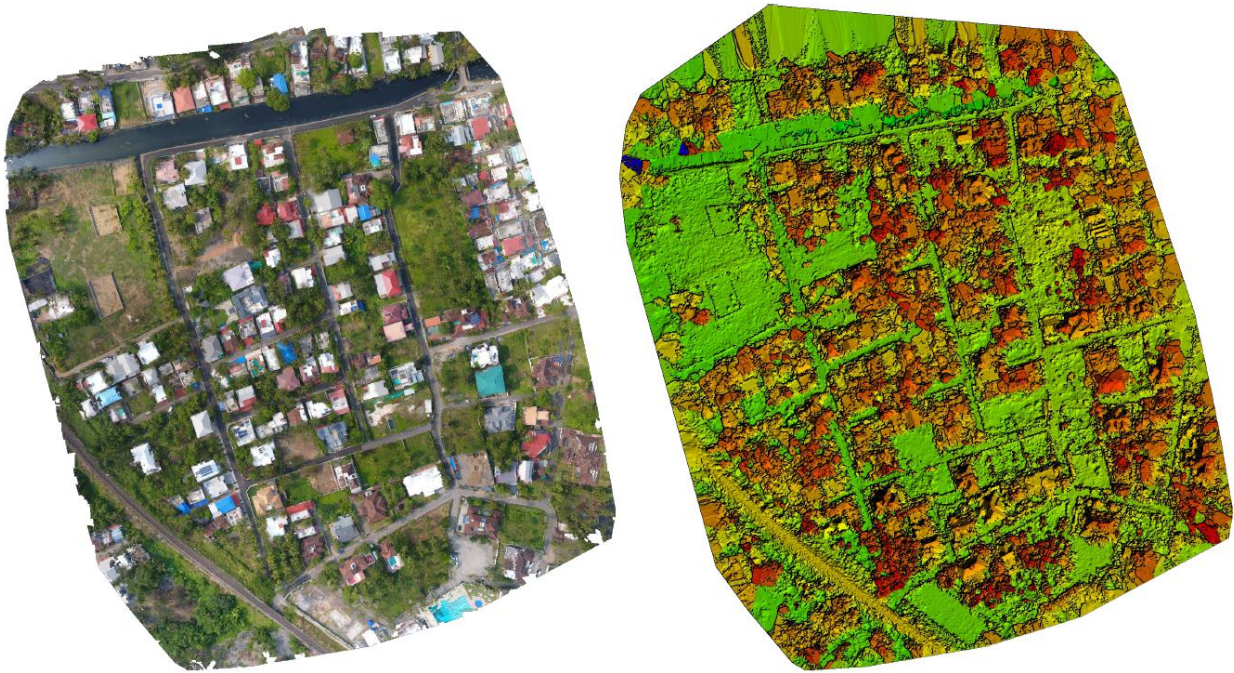
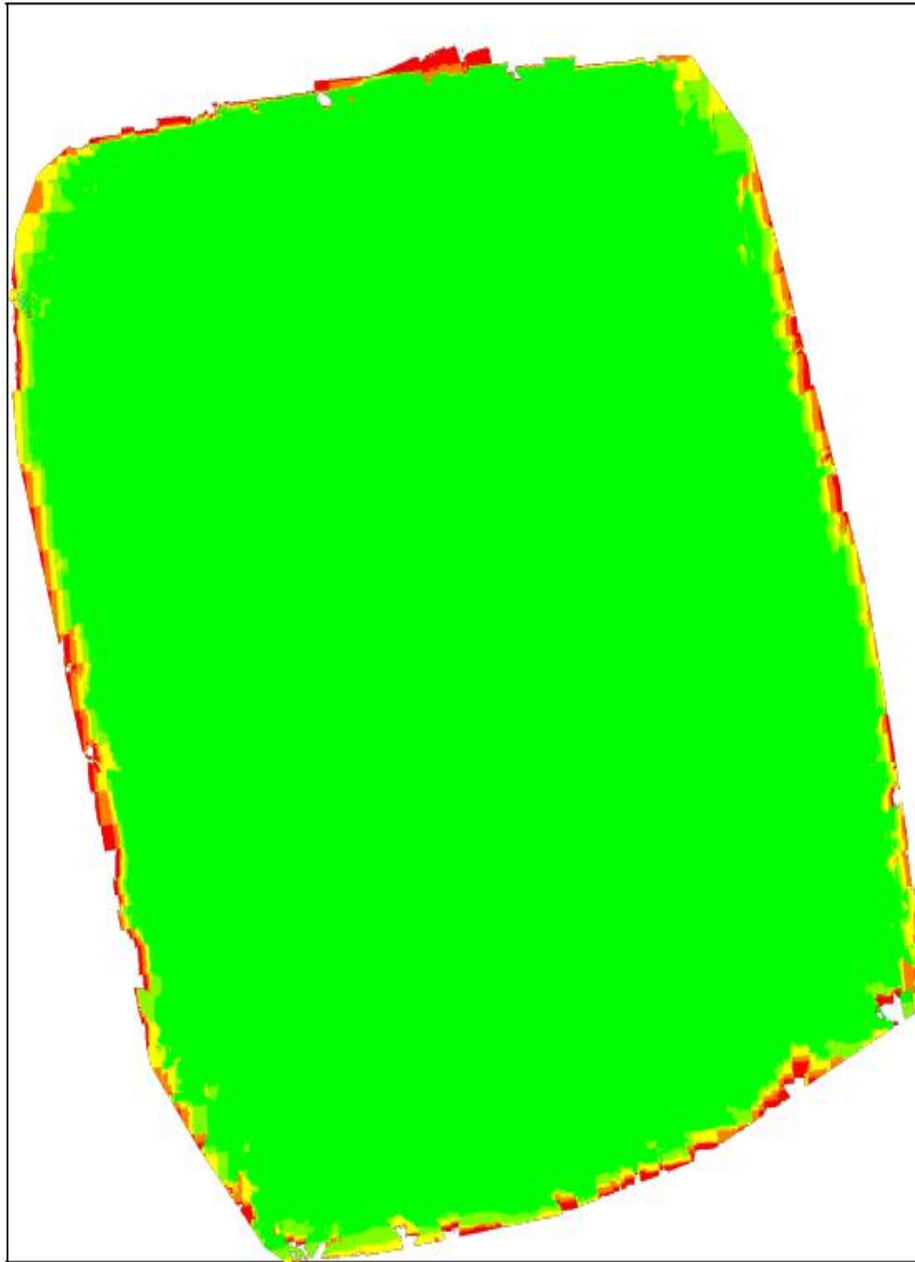

Figure 5.1.3 Orthomosaic and the corresponding sparse Digital Surface Model (DSM) pix4dmapper before densification

The Green line follows the position of the images in time starting from the large blue dot.

iii) Overlap



Number of overlapping images: 1 2 3 4 5+

Figure 5.1.4 : Number of overlapping images computed for each pixel of the orthomosaic

vi) Internal Camera Parameters

	Focal Length	Principal Point x	Principal Point y	R1	R2	R3	T1	T2
Initial Values	2285.714[pixel] 3.610 [mm]	2000.000[pixel] 3.159 [mm]	1125.000[pixel] 1.777 [mm]	0.00 0	0.00 0	0.00 0	0.000	0.00 0
Optimized Values	2396.431[pixel] 3.785 [mm]	1850.266[pixel] 2.922[mm]	1100.766[pixel] 1.739 [mm]	- 0.00 5	- 0.01 0	0.01 2	0.005	- 0.00 2

vi) Geolocation Details

Min Error [m]	Max Error [m]	Geolocation Error X[%]	Geolocation Error Y[%]	Geolocation Error Z[%]
-	-15.00	0.00	0.00	0.00
-15.00	-12.00	0.00	0.00	0.00
-12.00	-9.00	0.00	0.00	0.00
-9.00	-6.00	0.00	0.38	0.00
-6.00	-3.00	5.36	15.33	0.38
-3.00	0.00	40.23	31.03	57.85
0.00	3.00	52.87	36.78	41.76
3.00	6.00	1.15	15.33	0.00
6.00	9.00	0.00	1.15	0.00
9.00	12.00	0.38	0.00	0.00
12.00	15.00	0.00	0.00	0.00
15.00	-	0.00	0.00	0.00
Mean [m]		-0.000001	-0.000000	-0.000003
Sigma [m]		1.619554	2.716921	1.184272
RMS Error [m]		1.619554	2.716921	1.184272

vi) 2D Keypoint Table

	Number of 2D Keypoints per Images	Number of Matched 2D Keypoints per Image
Median	42864	15763
Min	31667	4725
Max	49587	27987
Mean	43025	16398

a) 2D Keypoint Table for Camera 4000x2250(RGB)

	Number of 2D Keypoints per Images	Number of Matched 2D Keypoints per Image
Median	31667	0

Min	31667	4725
Max	31667	4725
Mean	31667	4725

2D Keypoint Table for Camera 4000x3000(RGB)

	Number of 2D Keypoints per Images	Number of Matched 2D Keypoints per Image
Median	42872	15826
Min	37133	6419
Max	49587	27987
Mean	43069	16443

vi) *Bundle Block Adjustment (BBA) Details*

Number of 2D keypoint observations for BBA	4279887
Number of 3D points for BBA	1343183
Mean Reprojection Error (pixels)	0.244086

Conclusion

In the last decade, the combination of rapid development of low cost and small Unmanned Aerial Vehicles (UAVs), improved battery technology and conventional sensors in terms of cost and dimensions, led to new opportunities in environmental remote-sensing and 3D surface modeling. UAVs can be used to map the area of interest rapidly and at a relatively low cost, and provide high-resolution results. UAV based measurements are contactless which allows for highly visual representations of natural or manmade environment. They can be used to get information from places which cannot be easily (or safely) accessed, such as highways, rocky cliffs, remote locations, etc. As taking measurements does not interfere with traffic of work processes, low altitude photogrammetry can offer elegant control over quarries, landfills, highways or roads. UAV based mapping offers a completely new paradigm of what is considered to be land surveying. Surveyors can map huge areas of land, and make technical and business decisions later, focusing on anything from which survey maps to produce to the question of resolution and level of detail. Furthermore, if at later stage a more detailed survey map is required, one can extract additional measurements from existing aerial images without having to do any more field work.

Precision Agriculture

Precision Agriculture using drones, a new concept in crop management, has been applied in agriculture. The objective is to avoid applying the same management practices to a crop regardless of site conditions and to improve field management from several perspectives. Unmanned aerial vehicles (UAVs) provide high-resolution images of crops and when specific indices are applied, useful outputs for farm management decision-making are produced. Precision agriculture requires real time data and the ability of UAV's to fly over crops and quickly gather crop management data makes them a solution to farmer's need.

The goal of precision agriculture is to more efficiently apply a farm's limited resources to gain maximum yield. A primary method for doing that is to minimize variability of crop health within and across fields. By using drones to scout for weeds and pests, spot diseased plants or dry areas, and spray the right amount of fertilizer and pesticide, farmers can increase yield with less resources and environmental harm. The adoption of precision agriculture and

reduced-input farming technics entails higher level of input data, with enhanced spatial and spectral resolution, and increased frequency of information delivery. However, automation in the deployment of UAV sensing systems for operational in-field use, integration of visible, near-infrared and thermal spectral ranges, standardization of data collection, data processing and analysis workflow, production of readily available services, and credibility of reliable economic return from their incorporation into agronomical practices are components still relatively absent from the agriculture industry.

Precision agriculture is a farming management concept based on observing, measuring, and responding to inter- and intrafield variability in crops. Precision agriculture uses detailed, site-specific information to manage production inputs like water, nitrogen, and pesticides. Information technologies enable segmenting a farm into smaller units to determine the characteristics of each individual segment. Farmers generally apply more agrochemicals on the chance that good weather leads to bumper crop yields. The main goal of any precision agriculture remote sensing is to detect something in time to make a correction. Examples of things that could need correction include irrigation, plant disease, drainage, and crop damage. Drones have the capability to provide remote sensing data in near real time in the field, rather than the resulting lag from satellite and aircraft-based imagery. It's this increased speed of the imagery from drones that has the biggest potential for changing how growers respond.

The application of pesticides and fertilizers in agricultural areas is of prime importance for crop yields. Precision Agriculture using drones help to minimize wastage of pesticides required for the effective control of weeds, diseases and pests and to ensure that crops receive adequate nutrients, leading to more efficient and greener agriculture. This method can be considered as a management strategy that utilizes information technology with the aim of improving production and quality. It allows farmers to tend their farm, crop and practices from an entirely new perspective. The field adoption using drones can be represented as a five-step cyclical process that covers data collection, diagnostic, data analysis, precision field operation, and evaluation.

Normalized Difference Vegetation Index (NDVI) is an imaging technique used to visualize near infrared light, which happens to be a very good indicator of plant health and productivity. This project aims to explore the potential of UAV's using NDVI imaging for crop monitoring and assess the feasibility of the process by developing a UAV with a NDVI camera to create NDVI maps from the aerial crop images. Visual inspection, color estimation or mold localization has been used for determining the state and conditions of a crop, using physical sensors or using multispectral cameras. Drones can be used to apply nutrients and pesticides to plants, instead of using workers on foot, or tractors. Aerial spraying is much faster and cheaper than using traditional methods, such as tractors.

Literature survey

We came a long way from the hunters and gatherers in the past. Now, modern humans use technology as a new lifestyle. People today use technology to improve daily activities. Examples are harvesting vegetable and fruit products in farms. Farming is the first livelihood activity of humans. Past human ancestors learned to use crops to prevent hunger. The modern humans perform agriculture through technology. Our society uses agricultural machines to monitor and cultivate crops. Agriculture introduces one technology to improve farming activities. This is the Drones that monitors crops and cultivated farmlands.

Precision agriculture had its beginning in the middle of 1980's with sensors for soil organic matter and is currently developing exponentially. It began with farming by soil and has progressed to site-specific crop management based on grid sampling and management zones. Later, there has been increasing emphasis on real-time on-the-go monitoring with ground-based sensors. The accuracy of the images has become greater which allows evaluation of soil and crop properties at a fine spatial resolution at the expense of increased data storage and processing requirements. Precision agriculture tends to offer increased farm profitability by improving the crop production and through improved management of farm inputs leading to less environmental pollution.

The large amount of data and information that is being collected gives us more accurate and precise application of the inputs on a farm. This leads yet again to improved crop productivity and environmental quality. Drones encountered technical controversies in the past. These controversies help manufacturers develop better monitoring devices with new features. Drone became helpful in farming industries around the world due to its monitoring

functionality. The introduction of an Unmanned Aerial System (UAS) or Drones assists farmers to increase crop productivity. Using a Drone increases crop production that can be reaching to more consumers.

Sensors used

Optical sensors such as RGB, multispectral, hyperspectral, thermal infrared, and LiDAR can provide helpful information on crop growth and health. Because of their low cost and ease of image interpretation, multispectral sensors have been most commonly used. It has been used for crop health monitoring, crop emergence and yield estimation in range of irrigated. Multispectral sensors have also been used for detection of nutrient deficiencies in corn, wheat, soybeans and for weed identification in field crops.

As agricultural industry explores this domain, sensors for specific agricultural applications would require major validation efforts under various scenarios using ground reference methods. It applies specifically to the crop monitoring solutions offered by a range of agricultural service providers. Variation in sensor response during the crop season due to various climatic and non-climatic conditions need to be accounted for before using such data for production management decision making. In general, with the availability of commercial small UAS platforms that are rugged, reliable (in-flight operations), and are versatile (in terms of payload handling), major efforts are needed towards the development of sensors that have, a small form factor, light weight, larger field of view, versatility of triggering mechanisms, optimal image capture rate for adequate image overlap, easy calibration procedures/mechanisms, on-board data storage capability, less power consumption rate, and field ruggedness. source google



Fig 5.2.1: Realization of agriculture applications using sensors integrated with UAS

i) Visual Sensors

Visual navigation is using visual sensors. Comparing to the GPS, laser lightning, ultrasonic sensors, and other traditional sensors, visual sensors can acquire rich information of surroundings, involving color, texture, and other visual information. Meanwhile, they are cheaper and easier to deploy. Types of visual sensors include, monocular cameras, stereo cameras, RGB-D cameras and fisheye cameras. Basic uses of Visual cameras are:

- Aerial mapping and imaging
- Photogrammetry and 3D reconstruction
- Plant counting
- Surveillance
- Emergency response
- Surveying and land use applications

ii) Multispectral sensor

Multispectral imaging camera sensors on agricultural drones allow the farmer to manage crops, soil, fertilizing and irrigation more effectively. Multispectral camera remote sensing imaging technology use Green, Red, Red-Edge and Near Infrared wavebands to capture both visible and invisible images of crops and vegetation.

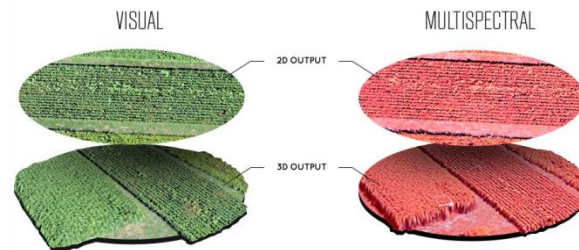

Fig 5.2.2: 2D and 3D image sets obtained from visual and multispectral cameras

iii) Thermal Sensor

Airborne thermal sensors can see hotspots and measure changes in land and plant temperature over time. Thermal sensors can also detect the presence of water due to its cooling effect, which can be helpful in spotting crop damage due to drought and/or seasonal issues. Thermal vision cameras make pictures or video from heat, not visible light. Thermal cameras detect more than just heat. Heat vision cameras detect the tiny differences in heat, as small as 0.01° Celsius. This information is then displayed as various colors on a display, in thermal software or apps.

As the temperature of an object increases, the wavelengths within the spectra of the emitted radiation also decrease. Hotter objects emit shorter wavelength, higher frequency radiation. Thermal properties of plant leaves are influenced by the internal structure, which contains a substantial amount of water per a unit of area.

The potential use of thermal sensors in agriculture includes:

- Nursery monitoring
- Soil salinity stress detection
- Plant disease detection
- Plant physiology analysis
- Evaluation of fruit ripeness
- Live stock Detection
- Water temperature detection and water source detection

iv) LiDAR Sensor

A Light Detection and Ranging (LiDAR) sensor mounted on an Unmanned Aerial Vehicle can map the over flown environment in point clouds. Mapped canopy heights allow for the estimation of crop biomass in agriculture. LiDAR is a precise remote sensing technology that measures distance by illuminating a target with a laser and analyzing the reflected light.

LiDAR sensors have mainly been used in agriculture in ground-based systems for mapping soil and crops. LiDAR mapping data can then be used to evaluate the impact of agricultural production methods LiDAR sensor system can be used to collect spatial data from crop-fields, which can be post-processed to derive canopy volume estimates and textural analysis of individual crop parcels.

LiDAR helps farmers to find areas where costly fertilizer is being overused, and also helps to create elevation maps of farmland that can be converted to create slope and sunlight exposure area maps. Layer information provided via LiDAR can be used to create high, medium, and low crop production area maps, and extracted data can help farmers to save on fertilizer, and generally optimize their efforts. LiDAR sensors are mainly used for the plant height monitoring.

v) Hyperspectral Sensor

Spectral imaging is the detection of light reflected by the crop with the use of specialized sensors. It is measured in spectral bands. The higher the number of bands, higher the accuracy, flexibility and information content. Hyperspectral technology with its higher detection capabilities due to higher number of spectral bands can develop solutions for almost any problem encountered in the field. Hyper spectral imaging in agriculture allows to significantly extending the range of farming issues and applications that can be addressed using remote sensing.

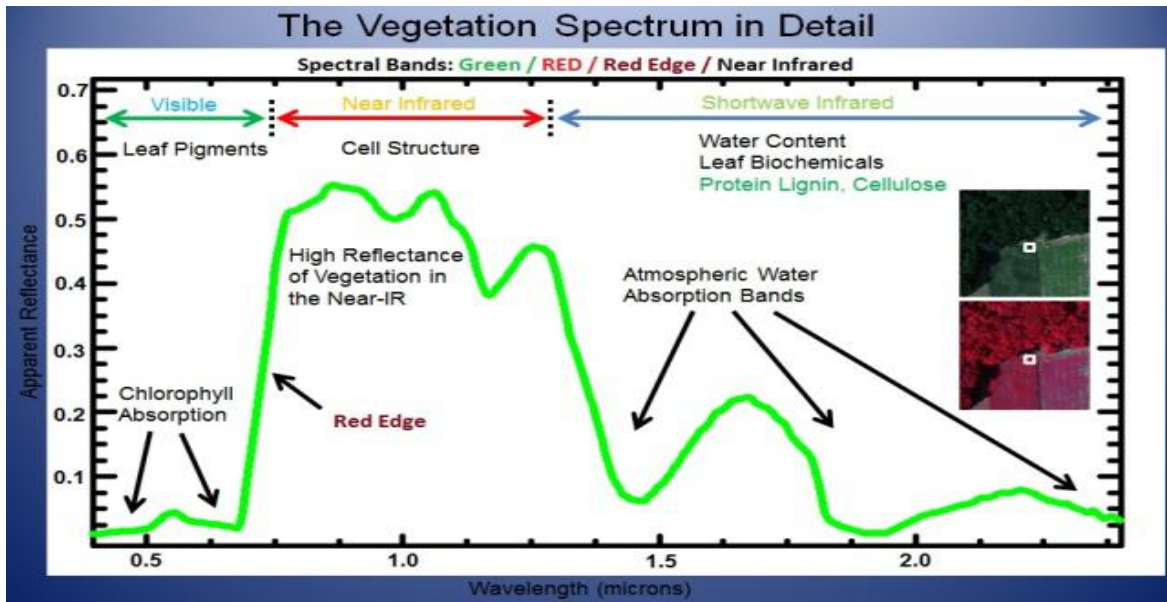

Fig 5.2.3: Vegetation Spectrum source google

Almost every farming issue changes a physiology of the plant, and therefore affects its reflective properties. Healthy crop and crop that is affected by disease reflect the sun light differently. Using hyper spectral imaging it's possible to detect very small changes in the physiology of the plant and correlate it with spectrum of reflected light.

Hyper spectral camera, which allows to make measurements of spectrum versus measurements done using multispectral cameras. High spectral resolution of data allows for detection and identification of inferring biological and chemical processes in crops, which opens up a full range of applications in precision agriculture. Hyper spectral imaging benefits in precision agriculture are:

- Plant health measurement
- Water quality assessment
- Vegetation index calculation
- Full spectral sensing
- Spectral research and development
- Mineral and surface composition surveys

Vegetation spectrum

The reflectance properties of an object depend on the particular material and its physical and chemical state (moisture), the surface roughness as well as the geometric circumstances (incidence angle of the sunlight). The most important surface features are color, structure and surface texture. The perceived color of an object corresponds to the wavelength of the visible spectrum with the greatest reflectance. These differences make it possible to identify different earth surface features or materials by analyzing their spectral reflectance patterns or spectral signatures. These signatures can be visualized in so called spectral reflectance curves as a function of wavelengths.

The Fig 5.2.3 show typical spectral reflectance curves of three basic types of Earth features: green vegetation, dry bare soil and clear water. Green, Red, and Infrared are the main ones used in agriculture. The Red Edge is also sometimes used for obtaining additional indices.

i) Vegetation Curve

The spectral reflectance curve of healthy green vegetation has a significant minimum of reflectance in the visible portion of the electromagnetic spectrum resulting from the pigments in plant leaves. Healthy vegetation will absorb in both the blue and red bands, giving rise to what is called the green bump of healthy vegetation.

Reflectance increases dramatically in the near infrared. Stressed vegetation can also be detected because stressed vegetation has a significantly lower reflectance in the infrared.

ii) Soil Curve

The spectral reflectance curve of bare soil is considerably less variable. The reflectance curve is affected by moisture content, soil texture, surface roughness, presence of iron oxide and organic matter. These factors are less dominant than the absorbance features observed in vegetation reflectance spectra.

iii) Water Curve

The water curve is characterized by a high absorption at near infrared wavelengths range and beyond. Because of this absorption property, water bodies as well as features containing water can easily be detected, located and delineated with remote sensing data. Turbid water has a higher reflectance in the visible region than clear water.

This is also true for waters containing high chlorophyll concentrations. These reflectance patterns are used to detect algae colonies.

iv) Multispectral Vegetation Bands

a) Green

The Green corresponds to the reflected energy in the 500–600 nm spectral band and has the greatest reflectance of a plant in this band. The reflectance peak is at around 550 nm. It has been proven that this spectral band is strongly correlated with the amount of chlorophyll contained in the plant.

In this visible portion of the vegetation spectrum, the reflectance curve of a healthy plant exhibits the greatest reflectance in a green waveband (in the range of 550 nm). This is why plants appear green to us. A chemical compound in leaves called chlorophyll strongly absorbs radiation in the red and blue wavelengths but reflects green wavelengths. Leaves appear “greenest” to us in the summer, when chlorophyll content is at its maximum.

In autumn, there is less chlorophyll in the leaves, so there is less absorption and proportionately more reflection of the red wavelengths, making the leaves appear red or yellow (yellow is a combination of red and green wavelengths). The internal structure of healthy crops act as excellent diffuse reflectors of near-infrared wavelengths. Measuring and monitoring the near-IR reflectance is one way to determine how healthy (or unhealthy) vegetation may be. Still most of the light in the visible spectrum reflected by a plant under stress is in the green range. Hence, to the naked eye, a plant under stress is indistinguishable from a healthy one. On the other hand, the difference can be seen in the reflectance of light in the infrared range, which is far less.

b) Red

Corresponds to the reflected energy in the 600–700 nm spectral band. The strong chlorophyll absorption in this band results in a low reflectance. Reflectance varies significantly in relation to factors such as biomass, LAI (Leaf Area Index), soil history, crop type, humidity and plant stress. For most crops this band gives an excellent contrast between the plants

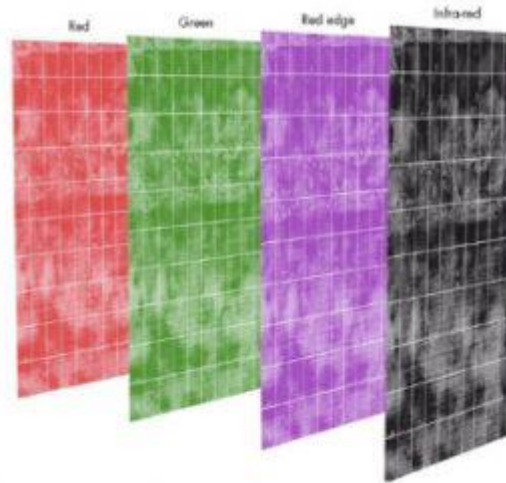

Fig 5.2.4: Different colours in vegetation band and the soil and it is extensively used for compiling most of the vegetation indices in agriculture

c) Red Edge

This a very narrow band (700–730 nm) that corresponds to the entry point of Near Infrared. It is the point of sudden change in reflectance, from strong absorption of Red to substantial reflection of Near Infrared. This band is very sensitive to plant stress and provides information on the chlorophyll.

- Crop health analysis
- Plant counting
- Water management

d) NIR (Near-Infrared)

Corresponds to the wavelengths in the 700 nm to 1.3 μm range, has the strongest reflectance of the bands studied. There is a very strong correlation between this reflectance and the level of chlorophyll in the plant. A highly significant variation of the reflectance in this band is produced when a plant is under stress.

- Along with the Red spectral band, infrared is extensively used for compiling most of the vegetation indices in agriculture NIR is sensitive to the leaf

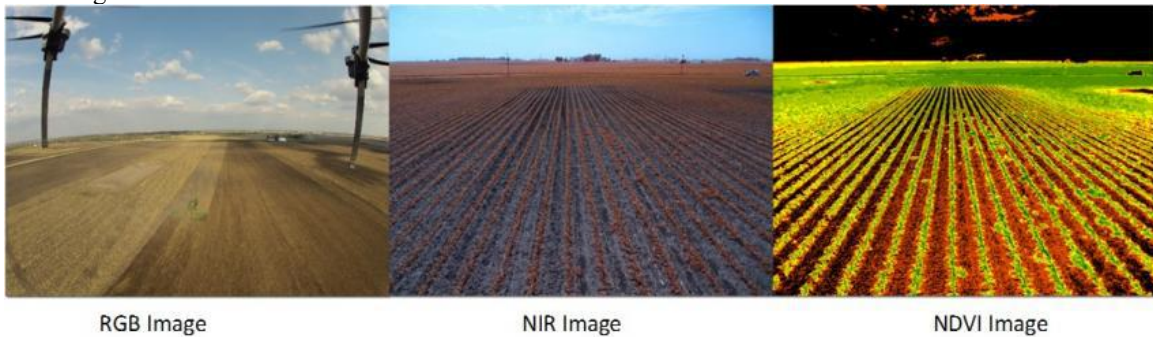

Fig 5.2.5: Images of crop field using different cameras source google

cellular structure and provides critical data to monitor changes in crop health.

- Soil property and moisture analysis
- Crop health and stress analysis
- Water management
- Erosion analysis
- Plant counting

Healthy vegetation absorbs blue and red-light energy to fuel photosynthesis and create chlorophyll. A plant with more chlorophyll will reflect more near-infrared energy than an unhealthy plant. Thus, analyzing a plants spectrum of both absorption and reflection in visible and in infrared wavelengths can provide information about the plants' health and productivity.

e) *Thermal Infrared*

Thermal infrared radiation is the part of electromagnetic spectrum which has a wavelength of between 3.0 and 20 micrometers. Most remote sensing applications make use of the 8 to 13 micrometer range. The main difference between thermal infrared and the infrared (color infrared – CIR) is that thermal infrared is emitted energy that is sensed digitally, whereas the near infrared (also called the photographic infrared) is reflected energy.

Agricultural application

Drone technology will give the agriculture industry a high-technology makeover, with planning and strategy based on real-time data gathering and processing.

i) *Planting Seeds*

With current advancements in drone technology, it is been able to decrease seed planting costs significantly. The current fleet of drones can plant up to 100,000 trees a day. The drones have two jobs in the planting. First, they fly over the land, mapping the terrain and collecting information about its topography and soil. This data is then processed by an algorithm to determine where to plant and what species of tree would thrive. Then, another set of drones is each given a batch of specially designed seed pods and sent out. Flying low over the ground, the planter drones follow instructions determined by the data on where to go and when to fire a seed pod into the ground. They're accurate to within centimeters.

This method of seed planting is almost 10 times faster than humans planting trees by hand and can potentially decrease overall costs by half. Utilizing drones to begin new crops is especially beneficial in locations where it might be particularly difficult for farmers to plant seeds in. During extremely hot times of the year, using drones would



Fig 5.2.6: Seed bomb drones source google

be a great alternative to having to manually plant them. Drone planting systems achieve an uptake rate of 75 percent and decrease planting costs by 85 percent. These systems shoot pods with seeds and plant nutrients into the soil, providing the plant all the nutrients necessary to sustain life.

i) *Spraying Fertilizers and Insecticides*

Drones spray fertilizer chemicals to crops. While spraying, Drones visualize the crops to show the actual fertilizer applied to it. Fertilizer spraying happens right after planting the seeds. Insecticides prevent animal or insect infestation to the farmlands. Humans are at risk for developing diseases when exposed to insecticides. They are machines that are immune to pesticide's chemical complications.

Agri drone is an octocopter designed for precision variable rate application of liquid pesticides, fertilizers and herbicides. It can carry up to 5kg of liquid payload with around up to 10 minutes of flight time for spraying applications. The intelligent spraying system automatically adjusts its spray according to the flying speed so that an even spray is always applied and through a combination of cooling and filtering designs indicates that expected lifespan of each motor is increased by up to three times in the dusty and extreme crop spraying environment.



Fig 5.2. 7: Spraying pesticides using quadcopter source google

Distance measuring equipment ultrasonic echoing and lasers such as those used in the light-detection and ranging, or LiDAR, method enables a drone to adjust altitude as the topography and geography vary, and thus avoid collisions. Consequently, drones can scan the ground and spray the correct amount of liquid, modulating distance from the ground and spraying in real time for even coverage. The result is increased efficiency with a reduction of in the amount of chemicals penetrating into groundwater. In fact, experts estimate that aerial spraying can be completed up to five times faster with drones than with traditional machinery.

By using a series of different distance-measure/imaging equipment like LiDAR, drones can effectively avoid obstacles during their flights. Initially, the way drones would navigate their surroundings would be through remote controls that needed to be navigated manually. I.e., if the drone pilot wasn't careful, the drone could easily run into a tree and crash. However, with new technology, this is easily avoidable. Tools like sensors that use ultrasonic echoing and LiDAR allow drones to avoid running into obstacles around them during flight. With that said, it's now feasible for drones to fly at low enough altitudes to spray pesticides and target particular sections of a field to distribute it accordingly. By using drones rather than pesticide-spraying planes, farmers can now target exactly which crops need pesticides and how much needs to be sprayed while the drones actually spray them.

ii) Crop monitoring

Vast fields and low efficiency in crop monitoring together create farming's largest obstacle. Monitoring challenges are exacerbated by increasingly unpredictable weather conditions, which drive risk and field maintenance costs.

Soil properties like moisture, organic matter, clay content, salinity and pH can be measured sensors mounted on UAVs. Remote sensing using UAV enables the collection of high resolution imagery to aid in the precision agriculture decision management process and has demonstrated the detection of crop water stress, crop yield estimation, phenotyping and disease detection. Using near-infrared, you can identify stress in a plant 10 days before it becomes visible to the eye. When a plant goes into stress, it's either due to a water or fertiliser shortage, or because it's being attacked by a pest. Photosynthetic activity decreases and that affects the chlorophyll. That's what the near-infrared sensor can detect, but our human eye can't see it until it's more advanced.

UAVs provide an easy and low-cost way for farmers to monitor their land. Especially on large tracts of land, monitoring crops on a regular basis takes a huge amount of time. Monitoring crops with drones allows farmers to pinpoint problems early on. With video recording technology, patterns in fields can be analyzed with computer software. The software is able to make sense of certain patterns that point to low nitrogen levels, disease, and irrigation problems. Spotting these problems early makes stopping them far easier. Farmers can apply solutions near instantly to stop a minor problem from becoming major.

In factories or corporate buildings, it's a lot easier to manage operations since everything is done within a fairly small vicinity. For farmers managing extremely large sections of land, things are completely different. Keeping track of every square meter of land simply wasn't feasible in the past. Fortunately, drones help change that. Having eyes-in-the-sky proves to be an especially powerful tool for farmers who have trouble keeping track of different metrics. The ongoing monitoring that drones bring to the table help give farmers updated information on exactly what's happening on their land.

iii) Analyze Crop Quality

Quality is always important for farmers. Improving crop's quality satisfies target market's needs. Drones assist farmers to improve the crop quality in their farmlands.

Drones are equipped with light processing devices to visualize the crops. The device provides farmers an idea about the crop's health. The device detects unhealthy crops to prevent shipping substandard products. The device analyzes the crop quality after sprayed with insecticides or medicines. This is to monitor the effect of the chemical substance to the crops. Farmers discard crops damaged by insecticides.

iv) Health assessment

It's essential to assess crop health and spot bacterial or fungal infections on trees. By scanning a crop using both visible and near-infrared light, drone-carried devices can identify which plants reflect different amounts of green light and NIR light. This information can produce multispectral images that track changes in plants and indicate their health. A speedy response can save an entire orchard. In addition, as soon as a sickness is discovered, farmers can apply and monitor remedies more precisely. These two possibilities increase a plant's ability to overcome disease. And in the case of crop failure, the farmer will be able to document losses more efficiently for insurance claims.

To monitor changes in plant health over time, drone images are processed to calculate a tracking index called NDVI (normalized difference vegetation index), which is a measure in the difference between light intensity reflected by the field in two different frequencies.

NDVI is the ratio of difference of near infrared (NIR) reflectivity and visible red reflectivity (VIS), by sum of NIR and VIS. That is,

$$NDVI = \frac{NIR - VIS}{NIR + VIS} \quad (1)$$

CCCI (canopy chlorophyll content index), detects canopy nitrogen levels using three wavebands along the red edge of the visible spectrum. Requires visible and near infrared cameras. Ortho-mosaic images can be processed with a variety of filters and map types to give you better insights into agro operation. Normalized Difference Vegetation Index (NDVI) compares light in the visual and near-infrared (NIR) spectra that reflect off crops to provide better indication of plant health than is visible with the naked eye.

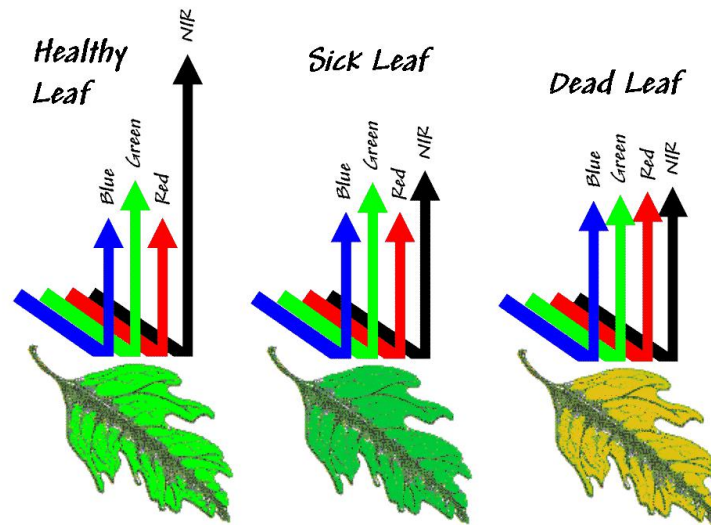

Fig 5.2.8: Stages of healthy leaf

i) *Herd Health, Security & Surveillance*

Often times cattle ranchers have to drive their stock to new fields for grazing and management. With limited resources, it's often hard to track the herd in an efficient manner, or cows become lost or separated from the herd. Using thermal surveillance drones can improve herd surveys considerably, locating the animals in the dark without having to use floodlights and vehicles which may spook the animals. Thermal cameras can also easily detect temperature in the stock, to identify sick animals and bring them in for healing. They can also detect potential predators, such as wolves or coyotes that may be a threat to aged, ill or young members of a flock.

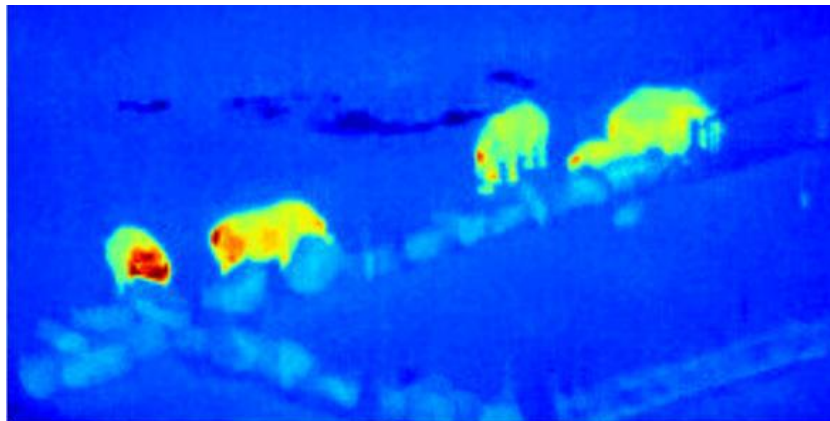

Fig 5.2. 9: Herds detected in thermal cameras source google

Drones can help monitor livestock from overhead, tracking the quantity and activity level of animals on your property. Watch for injured animals with real-time information from your drone and even use thermal cameras to identify animals with a fever and monitor livestock health.

UAV flies three or four times a day, monitoring the locations of the endangered species and transmitting a live stream to a laptop on the ground. This acts as a deterrent to poachers and also tracks the movement of all tagged animals. The animals are chipped with RFID tags giving each a unique identification in the database. Sensors on the drone can recognize individual animals and use on-board GPS to store an image tagged with location coordinates. This enables the Conservancy to collect data on animal movements and behaviour. Drones are a solid option for monitoring herds from overhead, tracking the quantity and activity level of animals on one's property. And they are

especially helpful for night-time monitoring due to the human eye's inability thus far to evolve to the point of seeing in the dark.

v) *Faster Detection of Weeds, Disease, and Pests*

Farmers know that some infestations can take over the entire field in as little as two days, so the faster you can identify and act, the better the outcome. If you wait for imagery from a satellite or manned aircraft, it may be too late. On the other hand, you can fly a drone whenever, wherever and find the solution before the problem finds you. Agriculture drones quickly pinpoint issues, such as weeds, pests, and fungi before they become a bigger and more expensive problems.

Traditional crop scouting involves gas-guzzling ATVs, trucks, or tractors; driving through your fragile fields; and walking to manually observe plants and find problems. With drones, you can see your entire field in one place, quickly make observations, enter the geodata into your GPS, and drive right into the problem area, without damaging your entire field.

vi) *Slope, Drainage, and Irrigation*

Drones make it easy to get a sense of slope and drainage of a field. Drones with thermal cameras display dry ground as a warm color and wet ground as a cool color so you can adjust irrigation to fit your field's needs. Drone processing software uses additional in-flight drone data (such as altitude and attitude) to triangulate distances to points on the ground, forming three-dimensional images or Digital Surface Models (DSMs) that can help you see low points in your fields where drainage might be an issue and drain tile might be beneficial.

High-resolution drone maps can be imported into your farm and agronomy management systems to make targeted nutrient or pesticide applications and generate variable rate prescriptions, decreasing inputs and maximizing profits. Digital Surface Models

(DSMs) display high spots in red and low spots in blue, so you can easily see where drainage may be an issue in your fields.

vii) *Drought Assessment*

The temperature of a plant canopy depends on the degree of heat stress and water supply, it is possible to determine the current status of plant water supply using thermal sensor. Depending on water availability, plants showing symptoms of wilting emit more longwave infrared radiation. In order to compare the thermal data in time and space, the CWSI index was developed. It was obtained by normalizing the canopy temperature using the minimum and maximum differences between the plant canopy temperatures and air temperatures.

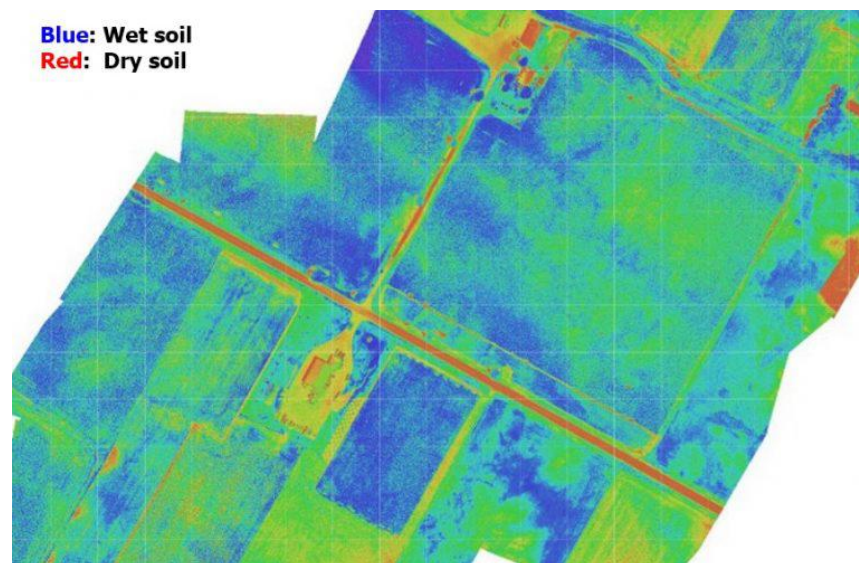

Fig 5.2.10: Thermal image of crop field source google

CWSI (crop water stress index), measures the temperature differentials to detect or predict water stress in plants. It requires a thermal imaging sensor and the use of a nearby weather station.

Drones with hyperspectral, multispectral, or thermal sensors can identify which parts of a field are dry or need improvements. Additionally, once the crop is growing, drones allow the calculation of the vegetation index, which describes the relative density and health of the crop, and show the heat signature, the amount of energy or heat the crop emits.

viii) *Biomass & yield estimation*

Remote sensing of soil moisture, using a UAV with high-resolution multispectral imagery has proven to be of great value for the crop yield and biomass. Crop yield can be a valuable indicator for farmers who want to estimate their predicted harvest and income. This can be done with a few different methods but the most efficient and cost effective way would be to use a UAV. The process of acquiring these estimations consists of a few steps, like geo referencing the images and classifying them into zones of homogeneous spectral response using unsupervised classification procedures. A correlation analysis shows then the correlation to the NIR, red, and green bands of the color-infrared (CIR) images and the normalized difference vegetation index (NDVI).

ix) *Crop Scouting*

Crop scouts perform a key service to farmers to ensure crop success. Drones help to identify crop issues, (i.e., pests, soil condition, disease, plant health, weeds, etc.) and to make recommendations for treatments/interventions. Drones periodically sample small areas and generalize their findings to the whole field.

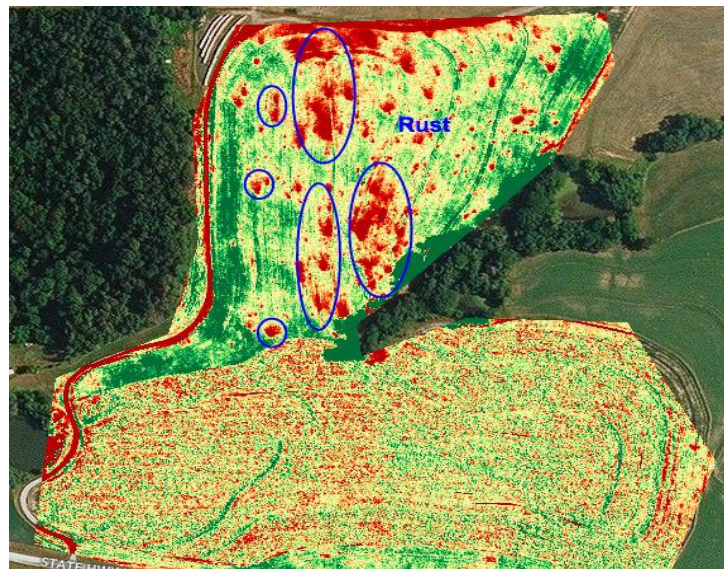

Fig 5.2. 11: Extent of rust fungus in wheat crop field source google

Using drone mapping farmers can pinpoint plant health issues such as parasites and fungi. Using drone mapping software areas of rust fungus in wheat crops can be detected. Clear sections of red coloration on the map enabled to identify the extent of the rust in the field.

x) *Crop Damage Assessment and Insurance*

When a nasty storm rolls through your farm, crop damage or loss is always a possibility. Ag drones help assess the crop damage more accurately and in less time than ground scouting. Rather than extrapolating damage in one section of your field, drones can quickly and accurately assess damage across your entire farm to ensure precise estimates for repairing the losses or for crop insurance to negotiate fair crop loss percentages.

xi) *Waterway & Fish Assessments*

Researchers can safely assess water depth, school sizes and other variables in a non-invasive manner. They may also use certain drones that can land on water to determine water quality as well.

xii) *Asset Inspection*

Asset inspection should be done regularly to prevent any faults or issues as early as possible, but current methods can be very time consuming, labor intensive, and even dangerous. Using drones to inspect assets such as grain bins, barns, or other buildings and equipment can help accurately inspect more efficiently and effectively. UAV enables

you to fly manually and capture live video from a higher vantage point and has a linear survey option to easily fly alongside fences and roads. Save flight missions to fly again with the touch of a button for future, regular inspections.

xiii) Overall Analysis of Crop Field

Agriculture is one industry where the importance of big data isn't emphasized enough. Using hyperspectral imaging technology, farmers can attain incredibly useful information that would help them maximize their operations. Depending on the imaging method, drones can help farmers do the following: assess crop health, spot fungal infections on trees, locate growth bottlenecks, locate poor irrigation, and gather general information on environmental conditions. With such a diverse range of actionable information available at a farmer's disposal, they can make informed decisions based on concrete data. Rather than having to make guesses on what the landscape will look like in the future, farmers would instead be able to make predictions.

Advantages

Although drone technology is still modifying production to increase ease of use and lower prices, these machines already have the potential to go a long way towards improving farmers' bottom lines and the environment. Key benefits of drone use in agriculture:

i) More information, less time

One of the major benefits of drones in farming is ability to scout farm fields both quickly and efficiently. Rather than having growers evaluate fields manually on foot or by tractor, this technology allows farmers to gain immediate knowledge about the status of their fields in shorter periods of time.

This information can be gathered whenever and wherever it is needed, minimizing the response time required to address issues and maintain crops.

ii) Improving crop health and efficiency

New drone technology is very effective at collecting data to help farmers improve crop health. Equipped with sensors, drones flying over a field can collect plant height measurements by gathering range information from the plant canopy and the ground below. By measuring near infrared wavelengths through a multispectral sensor, drones can also create vegetation index images, indicating which plants are healthy and absorbing maximum sunlight.

Drones also create satellite maps that can help farmers make decisions about fertilizer – a major concern of farmers, as fertilizer represents up to 50 percent of input costs. By using high-tech sensors to absorb near infrared wavelengths, drones make maps that can show where phosphorous and nitrogen might be needed – or where there is an excess of nutrients. In this way, more nutrients are being applied where they are needed most, as more fertilizer is absorbed by plants when it is applied precisely. This level of detail can help farmers increase production and efficiencies that lead to higher yields.

iii) Water efficiency and other environmental benefits

Thermal cameras are able to detect cooler, well-watered field regions as well as dry hot patches. Farmers can use this data to adjust field irrigation and avoid wasting excess water. This ability to increase water optimization is particularly valuable in drought-stricken areas. And by increasing water and fertilizer efficiency, drone technology also helps reduce excess fertilizer that runs off into nearby rivers and streams. Less runoff decreases the algal blooms and dead zones in our water systems.

iv) Cheaper Imaging

For fields less than 50 hectares in size, drones are considerably less expensive than satellites or manned aircraft surveillance.

v) Greater Precision

Drone cameras take centimeter-level images that reveal much more detail about a crop's condition.

vi) Reducing Farm's Operational Costs

Labor costs are reduced by regular use of Drones in agriculture. Drones improve the quality of the crops before they are distributed to the target markets. The device prevents any infestation to the crops regularly.

The UAV acts as alternative manpower to the farmlands. They assist in visually monitoring the farmlands. Drones are alternative quality detector system that reduces cost. This is to prevent rejected crops reaching target markets. This can eventually offset the cost of buying the Drones. Farmers may even be able to avoid losses incurred due to infestations or diseases on the plants.

vii) Earlier Detection of Problems

Drones survey more frequently, weeds, pests and other abnormalities are detected earlier.

viii) Total-Field Scouting

Instead of riding an ATV around the perimeter to scout perhaps 5% of a field, now every field can be scouted 100% using drones.

ix) 3D/Volumetric Data

Drone images can be used to calculate the volume of piles, holes, hills and patches. These can be compared to Infrared images to detect density issues like hot spots in a crowded beet field, or to identify contour problems such as north slope shade issues.

x) More Frequent Index Reporting

drones offer a cost-effective way to monitor crops more frequently for key indices like CCCI, CWSI and NDVI.

Conclusion

Agricultural drone have the potential to improve the crops and helps in providing an insight about the disease management technique through imaging and sensors. It will also provide help in the monitoring of irrigation and water supply by predicting the availability of water through glaciers. Agricultural drone can help the farmers to transform the agriculture industry.

Drones in agriculture make important necessities for the farmers. The device assists farmers to visualize their crops across their farmlands. The technology prevents any risk on losing crop's productivity. Farmers usually observe an increase in investment returns after they start using Drones. The idea of having an eye in the sky gratifies agricultural production for farmers. Drones provide an alternative eye above the ground towards the crops

The future of precision agriculture with UAVs are very exciting to correctly identify these highly engineered, safe and valuable tools that will increase profitability for future crop production.

5.3 UAV-Borne Thermal Imaging

UAV-borne thermal imaging involves the determination of ground surface temperature from thermal infrared measurements deploying an unmanned airborne vehicle (UAV). A large variety of UAVs is available and applied for different military and civil tasks. UAV-borne thermal imaging provides spatially distributed information of the ground surface temperature. In contrast to satellite or ground based measurement, the usage of a UAV allows us to obtain spatially distributed and geometrically highly resolved information on the ground surface temperature without the need to access the ground. The area can be flat or hilly, and steep walls and hillsides can be investigated easily.

UAVs set for the visible spectrum, thermal imaging camera and control elements that enable the user to quickly check a large area of the whole power plant. During the flight, it is possible to monitor live images, to produce a fully radiometric record or sequence the images of the whole flight. Records can be then analysed by the software, which has advanced measuring functions and the option to easily and quickly produce reports.

Introduction

Thermograph is a technical field dealing with the issue of contact-free determination of the allocation of the temperature field on the surface of the measured body. Special measuring devices, known as thermal cameras are used for this purpose. A thermo-camera is able to state the surface temperature of the measured objects within a few meters (at a sufficiently high emissivity value). Using a thermal camera, the inspection can unearth problems that cannot be seen on a traditional camera and can lead to serious problems in the near future.

Infrared radiation, which is a portion of the electromagnetic spectrum, is emitted by all objects with a temperature greater than absolute zero. The amount of radiation emitted increases with the temperature of the object, and so variation in temperature can be picked up by infrared sensors mounted to unmanned vehicles such as UAVs (unmanned aerial vehicles) and used to build up an image. Humans, animals and other heat sources will stand out against a cooler background.

Infrared (IR) cameras and visible light cameras may be mounted on the same unmanned vehicle payload in order to capture thermal and visible data in the same flight or journey. The cameras will typically be combined with a multi-axis gimbals to provide maximum stability during image capture, reducing the effect of vibrations, sudden impacts and movements. Several drone manufacturers provide a complete thermal imaging solution consisting of a UAV, stabilizing gimbals and imaging payload.

A signal processor can be used to map the variations in infrared energy, computing a temperature value for each pixel and mapping this data to visible colors. A visible picture can thus be built up, either using grayscale or full RGB color. Still images as well as streaming video may be captured at a range of resolutions. The data may also be saved and imported into post-processing software, allowing for further analysis and generation of statistics and other information.

Applications for unmanned thermal imaging systems include searching for and monitoring humans for security, search and rescue, and law enforcement, as well as animals for wildlife conservation. Thermal imaging can also be used to detect gas leaks and insulation failures and monitor the flow of heat energy for homes or industrial premises. Large banks of solar panels can also be scanned quickly and efficiently for defects by a UAV equipped with a thermal imaging camera payload.

The thermal imaging system is designed for assembly on the drone (UAV). The set is light, mobile and fully controlled using a standard RC controller. The system combines two camera systems a camera for visible spectrum and a thermal camera. The servicing software enables remote switching of camera regimes, record radiometric videos and to produce static images in the visible and infra-red spectrum. The operator sees any objects under the drone in real time and can analyze the records in order to identify the requirements.

Thermal imaging and camera technology

Heat vision cameras or thermal imaging cameras are in fact really heat detecting sensors. These thermal cameras are also known by various names including thermal camera, heat vision camera, thermal vision camera etc.

Thermal vision cameras make pictures or video from heat, not visible light. Heat (infrared thermal radiation) and light are both parts of the electromagnetic spectrum. However, a camera, which can detect visible light will not see thermal radiation and vice versa.

Thermal cameras detect more than just heat. Heat vision cameras detect the tiny differences in heat, as small as 0.01° Celsius. This information is then displayed as various colors on a display, in thermal software or apps.

Infrared radiation occupying the portion of electromagnetic spectrum in the band of 0.9 – 14 is emitted by all objects at temperatures above absolute zero. IR camera represents the captured radiation as a thermogram, a gray or pseudo colour thermal image that depicts thermal variations across an object or scene. IR cameras are based on two laws, the total radiation law and the Stefan–Boltzmann’s law. Total radiation law states that the amount of incident energy is equal to the sum of absorbed, reflected and transmitted energy. Stefan–Boltzmann’s law takes the form,

$$W = \epsilon\sigma T^4 \quad (1)$$

which states that the total radiant energy (W) of a body is proportional to the emissivity (ε) and to the fourth power of temperature (T). As the temperature of an object increases, the wavelengths within the spectra of the emitted radiation also decrease. Hotter objects emit shorter wavelength, higher frequency radiation.

Thermal radiation can occur through matter or through a region of space that is void of matter (a vacuum). The heat received on Earth from the Sun is the result of electromagnetic waves traveling through the void or vacuum of space between the Earth and the Sun.

i) *Scientific Explanation Of Thermal Radiation*

Thermal radiation or heat, is the discharge of electromagnetic waves from all matter, which has a temperature greater than absolute zero (−273.15° Celsius). It converts thermal energy into electromagnetic energy.

All objects radiate energy in the form of electromagnetic waves. The rate at which this energy is released is proportional to the Kelvin temperature (T) raised to the fourth power.

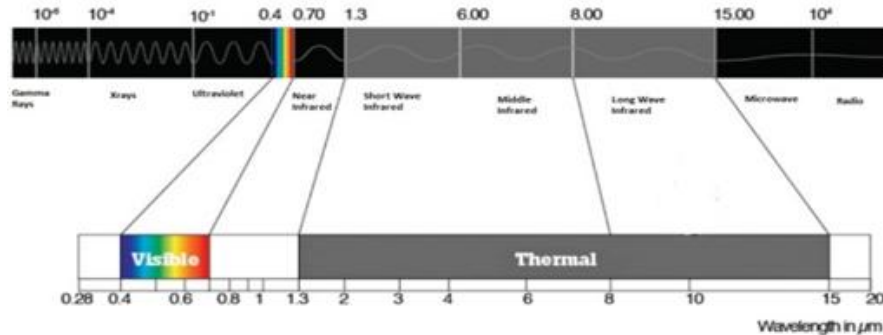

Fig 5.3.1: Electromagnetic Spectrum source google

Thermal energy consists of the kinetic energy of random movements of atoms and molecules in matter.

These atoms and molecules are composed of charged particles and kinetic interactions among matter particles which result in charge-acceleration and dipole-oscillation.

This results in the electro dynamic generation of coupled electric and magnetic fields, resulting in the emission of photons, radiating energy (thermal radiation) away from the body through its surface boundary. Most thermal cameras produce a video output in which white areas indicate maximum radiated energy and black areas indicate lower radiation. The gray scale image contains the maximum amount of information.

Uses of thermal imaging uavs

Here are some of the best uses for heat vision cameras on UAVs. The list is growing all the time. Drones with on-board thermal cameras save time, money and are also a very safe method for inspecting dangerous equipment.

i) Fire Fighting

After a fire seems to have burned itself out, it can still be smoldering in places that are difficult to detect by the naked eye. Using aerial thermography, fire fighters can see where those lingering hot spots are, and make sure they keep themselves from harm.

Aerial thermography can also help identify the location of fire victims, either within a house or a forest fire, so that fire fighters know where to focus their energy and time.

For several decades thermal cameras have been an indispensable help for fire fighters worldwide. The LWIR thermal camera does not record visible radiation but long-wave infrared radiation that penetrates smoke much better. It can search for the centre of a fire, as well as persons lost in the smoke or fog. A thermal camera together with a light and easy to control drone can be a very useful tool for rescuing human lives.

Particularly valuable for firefighting, drones with heat vision cameras give incident commanders the ability to see through smoke and keep track of their personnel in large fire scenes. Fire crews will know exactly where the fire is hottest and when the fire looks to be out, a thermal equipped drone will be able to give definite confirmation of the heat been dissipated from the scene.

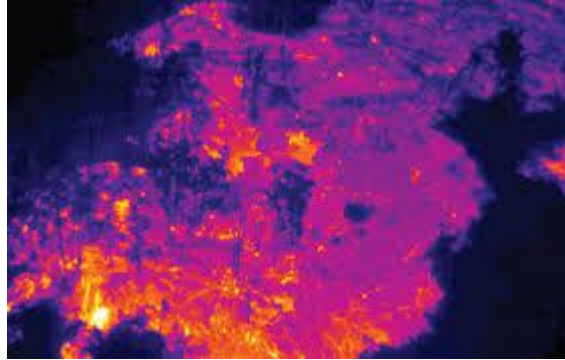

Fig 5.3.2: Thermal image of forest fire taken from UAV source google

i) **Search And Rescue**

A drone with thermal camera is a must have piece of equipment for rescuers. The thermal camera can be used both in day and night rescue missions. Drones can view and cover hundreds of acres in minutes. In daytime, the thermal radiation from a missing person on a mountain will stand out much more than the image from an ordinary standard video camera. A person may be wearing the same color clothing as their surrounding making it difficult for a standard video camera to detect the missing person. By a thermal camera, an object with different temperature can be detected within a distance of several kilometers. It should be noted that a potentially dangerous object may not just be a living creature and can also be a car or other form of transport or perhaps the centre of fire. It is a high-security risk that poses a risk every day to humans and property. By using infra-red radiation and thermal cameras, safely guarding of objects, people and property becomes easier and more reliable. All objects warmer than absolute zero emit infra-red radiation that can be detected by thermal imaging systems separately from the mentioned interference conditions.

The system helps to find drowning man in water just as well as a person trapped in by fire and smoke because they cannot be seen. UAVs are rapidly deployed to effectively search a large body of water immediately upon arrival. A UAV can complete the search, locate the victim, and even deliver a PFD or tag line for victim retrieval. While the boats are being launched and the lights are going up, your UAV will already have the victim in sight. When deployed with the thermal imaging system, it will be able to easily locate any victim above the water surface in complete darkness or even if they have been obscured by brush or other debris.

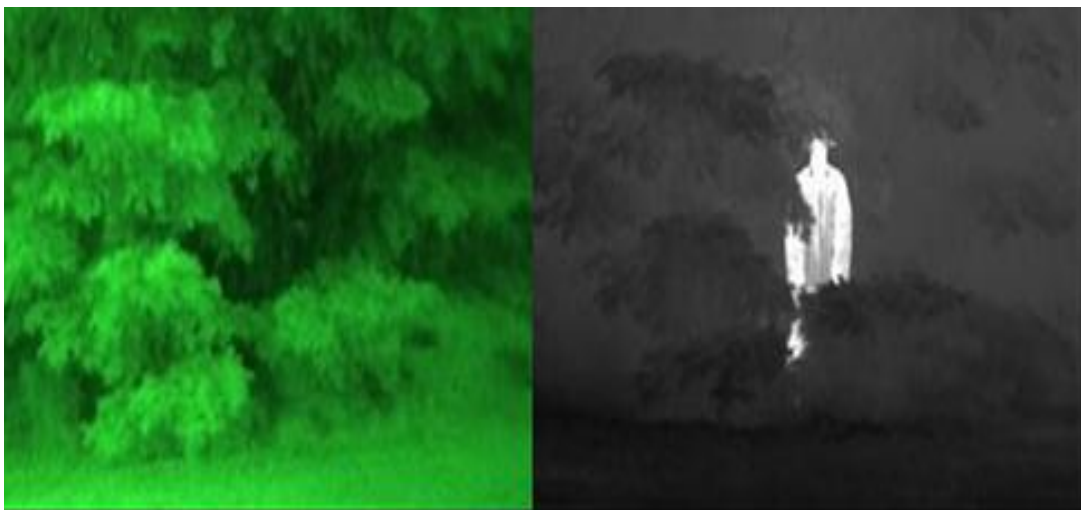

Fig 5.3.3: Human spotted in forest using thermal camera source google

Flying thermal camera inspections can be recommended for any safe inspection, for localizing the centre of fires, checking objects and areas and for searching for missing persons. Checking by drone is fast and undemanding and reduces the time required for intervention while increasing the probability of rescuing people and saving property. Since drones can cover a huge area of space in a short period of time, using aerial thermography to find people lost outdoors not only makes sense, it can potentially save lives.



Fig 5.3.4: Drowning man detected in water body source google

i) Detection and Recognition of Diseases Effected Livestock

General monitoring of livestock with conventional drone cameras gives more detailed cattle health diagnostics with thermal cameras. Internal body temperature can be calibrated from infrared radiation by means of molecular movement within an object and its resistance at the surface. Increased flow of white blood cells to a stressed area generates heat and is detected by the camera.

ii) Gas Leak Detection

Gas leaks from process and transport systems are common problems, that cause health, safety, and environmental issues, as such they are under the continuous enforcement of government regulators. Finding and repairing leaks quickly and effectively can provide major economic value by allowing you to avoid regulatory fines and reduce product loss.

Thermal imaging cameras can visualize and pinpoint gas leaks without the need to shut down the operation. Aerial monitoring of vehicles and industries, help to reduce the greenhouse gas contributor and protect the public from explosions and other harmful effects caused by emissions by taking precautions and adaptive methods according to the information's given by the system.

iii) Solar Panel Inspection

During production and then during the installation and operation of solar power plants, defects can occur that affect the service life or restricts the performance of the panels. The most well-known material defect is the so-called swirl defect, which is caused by the injection of oxygen admixtures into the material during the production of silicon ingots.

Most of the defects result in the occurrence of hot places, known as hot spots. This is where there is an increased recombination of electrons and holes. Energy released during this process is radiated into the space as heat. These spots report excessive heating and the thermal difference compared with good cells can be higher than 50°C. This

often leads to irreversible damage to the defective cell, as well as to the whole panel. Inspection of individual photo voltaic cells is usually a difficult task. The omission of regular inspection once a year can have fatal consequences in the form of fire.

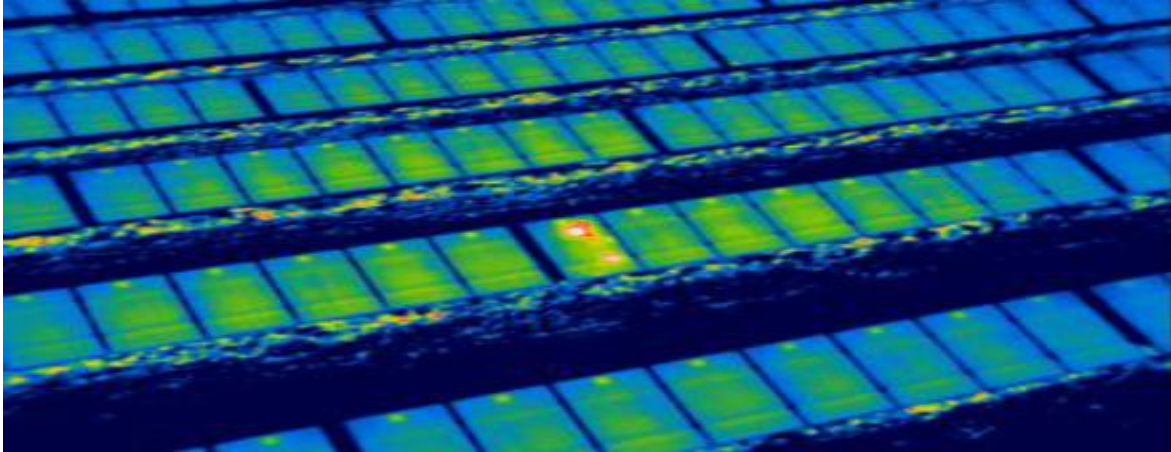

Fig 5.3.6: Thermal image of Solar power plant source google

If a solar panel is malfunctioning, this could mean a huge daily loss in potential energy gathered. But manual inspections are time consuming, and cost prohibitive. Using aerial thermography, an entire field of solar panels can be inspected quickly, checking for any hot spots where there might be problem areas.

When the alternatives are either doing the inspection by hand, or not doing it at all (which could risk losing huge amounts of potential energy), the cost-benefit analysis alone should help commercial pilots secure this kind of work in a snap.

Drones with thermal cameras can scan large solar panel installations in a few minutes allowing the operator to isolate and measure potential problem areas with a single aerial view. Solar farm inspections are almost impossible from the ground.

iv) Power Line Inspection

Electrical power stations produce AC currents with voltages of several thousand volts. Individual electrical power stations are connected to the distribution network by overhead lines. The element that connects the transmission and the distribution part of the distribution network are the transformer stations.

One of the most frequent failures in the distribution network is the overheating of individual components due to transition resistance. Due to the increase in series resistance, there are energy losses in the form of what is known as heat loss. It is not only economic problem but also a security problem, due to the further worsening of parameters, the temperature of the damaged joint can increase its

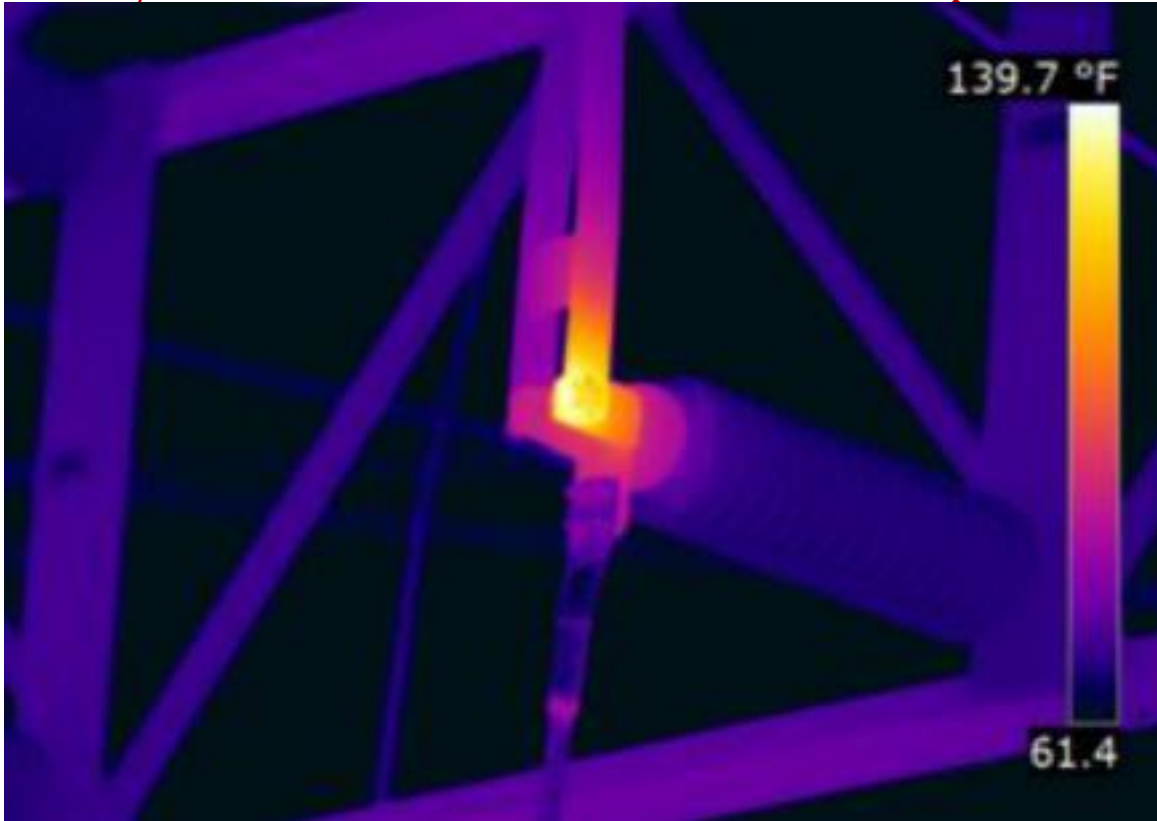

Fig 5.3.6: Thermal image of stated joint source google

temperature until a fire breaks out that may be highly destructive due to the high voltage. Transition resistance on the high-voltage distribution line leads to local heating of the stated joint. This problem results in energy losses and can result in fire breaking out in the future.

By detecting weak points in the transmission and distribution network, which is a highly complex system of lines of interconnecting electric energy sources, drones equipped with thermal imaging systems can identify problem areas before a breakdown or fire happens and prevent the fire from happening.

v) *Mining*

In the case of coal mining, often coal is stored in vast quantities in large storage containers. This can lead to high risk of a fire. It is very important to carrying out temperature monitoring of these coal containers as self-ignition can easily take place.

Other mining operations have large conveyor belts, a drone with thermal camera is the quickest way to monitor the health of the equipment. When equipment is stressed, it will show up hotter on a thermal image than previous. Thermal imaging can help detect equipment which is under stress and at some point will break.

vi) *Cell Tower Inspections*

Just as with power lines, aerial thermograph can also help detect problem areas in cell towers. This is yet another scenario where the only alternative would be manual inspection, which can be costly, as well as dangerous for the people who have to climb up and do the inspection.



Fig 5.3.7: Cell tower inspection using drone

i) Cultivation and Phenotyping of Cereals

The process of cultivation leading to the target properties of new cereal varieties is time-consuming due to the need to characterize a large number of potential gene resources. Genetic resources of minor cereals are tested in three-year seed-beds with elementary evaluation according to the applicable methodology of work with collections of genetic resources.

Availability of modern technologies of thermo graphic imaging from the UAV platform offers new possibilities for description of genetic resources, extension of the range of classifiers, in terms of thermal behavior of plants in relation to transpiration response of plants.

Preliminary analysis of the data indicates usefulness of this approach for the process of cultivation and phenotyping where the varieties have specific symptoms and significant differences in the areas of both visible and infrared radiation.

vii) Pipeline inspection

The issue of thermo graphic pipeline inspection applies to long-distance piping systems supplying variable media with a temperature different from the temperature of the surrounding atmosphere. By using thermo graphic systems, it is possible to determine and localize defects to pipeline insulation and leaks of the transferred media. In some cases, leaks can even be determined and localized in underground pipelines.

The reliability of the piping can suffer through poor design, improperly selected material or a defective construction of the whole transport system or from unexpected conditions when in the operation. The damage can be reflected as weakening of the cladding on the external insulation and leaks of heating energy, as well as breaks in the piping and the loss of the transported medium.

Due to the risk of losses caused by defects in the piping system, it must be regularly and carefully checked. UAV with a thermal camera flies above the whole length of the pipeline while recording and displaying the monitored scene in real time. It is easy to identify where the insulation is damaged and heat losses occur.

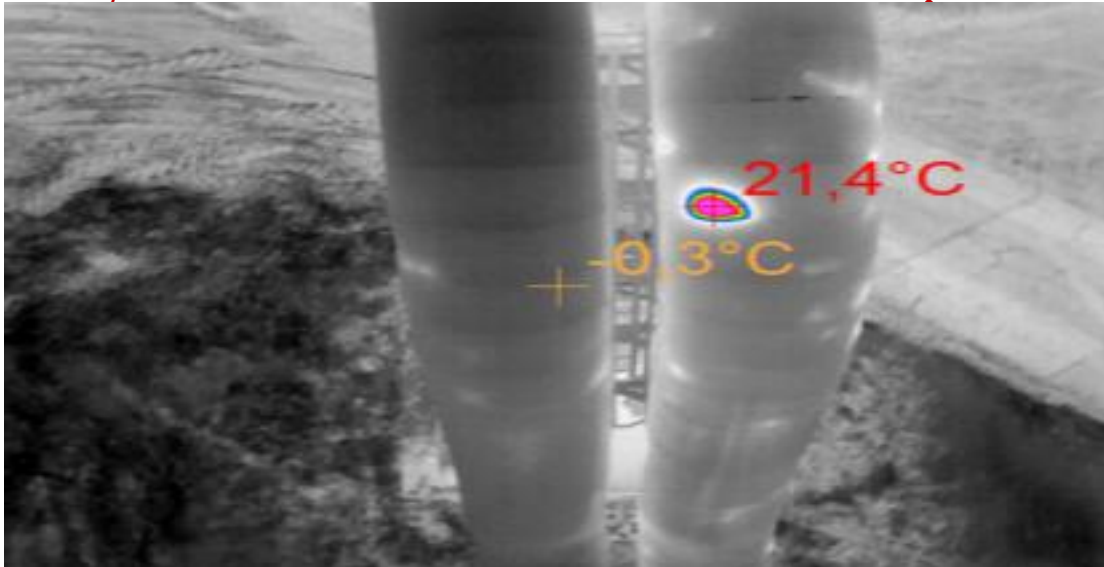

Fig 5.3.8: By using thermographic systems leaks are located source google

The system combines two camera systems – a camera for visible spectrum (for inspection of visible defects on the piping) and a thermal camera (for detecting hidden defects). The servicing software enables to remotely switch camera regimes, to record radiometric videos and to make static images in the visible, as well as the infra-red spectrum. The operator sees objects under the drone in real time or can analyse records to identify damaged areas.

viii) Defense Systems

Thermal imaging due to its various advantages has a large number of applications in military and defense. It is popularly used by the army and navy for border surveillance and law enforcement. It is also used in ship collision avoidance and guidance systems. In the aviation industry it has greatly mitigated the risks of flying in low light and night conditions. They are widely used in military aviation to identify, locate and target the enemy forces. Thermal imaging is widely used by the naval systems for navigation purposes to avoid ship collision during night and for monitoring the coastal areas to curb any unlawful activities. A typical example of coastal surveillance is shown in Fig. 5, thermogram of a motor boat approaching the shore during night.

Motion detection is an important task of Automatic Target Recognition (ATR) and perimeter monitoring systems. ATR is the field of science to detect, track, classify targets from video and signal streams. Perimeter or border monitoring mainly consists of detecting any unwanted or unexpected movement of person or vehicles in and around the area under surveillance. Thermal imaging has become an integral part of these systems because of its ability to operate in all weather conditions.



Fig 5.3.9: Coastal Area Surveillance source google

ix) Target Tracking

Automatic detection and tracking of interested targets from a sequence of images obtained from a reconnaissance platform is an interesting area of research for defense related application. The airborne images obtained from an UAV are analyzed in ground control station. By using the thermal images, all weather and night operation are possible. Visual and thermal image fusion is done and the fused image is given for target tracking.

x) Building And Roofing Inspections

Thermography can allow pilots to perform a simple energy audit of any building, either someone's home or a large corporate structure, in order to determine where there might be excess heat, or where heat might be escaping. In thermal imaging system, the thermal difference between a dry place and a place with penetrating moisture, fully identifies discovers where moisture has penetrated. During the heating season, the thermal camera can also identify areas that are poorly insulated and where there are thermal escapes. These areas show as warmer than the surrounding parts of the roof. **The system can measure temperature at the central point, as well as in the local minimum and maximum.** Minimum and maximum are localized using a blue (minimum) and red (maximum) cross. This function can also be used to navigate drones because the system automatically shows where the largest potential problem is located.

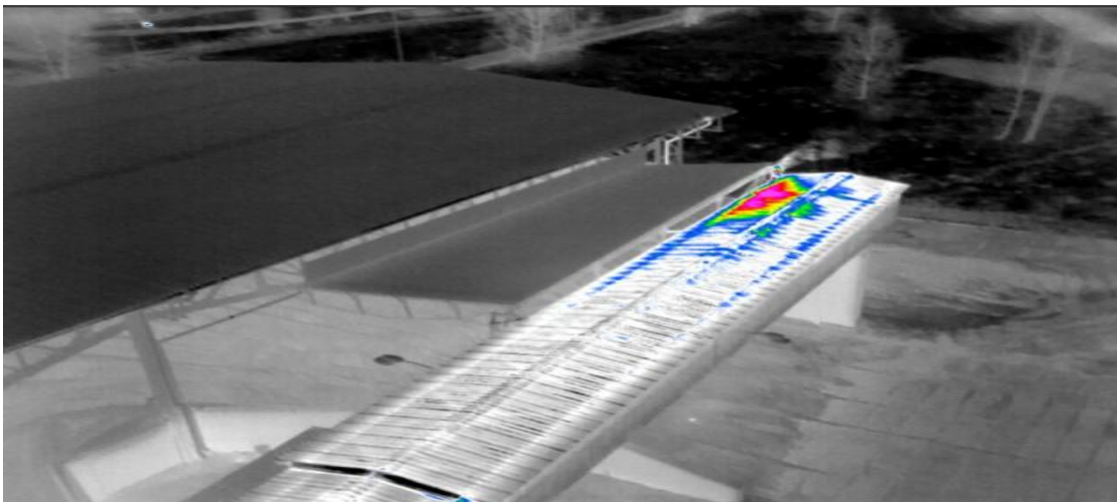

Fig 5.3.10: Defected areas seen in red colour source google

Conclusion

Thermal imaging cameras produce a clear image in the darkest of nights, in light fog and smoke and in the most diverse weather conditions. There has also been an increased interest in thermal imaging for all kinds of security applications, from long-range surveillance at border crossings, truck and shipping container inspection, to the monitoring of high-security installations such as nuclear power stations, airports, and dams. Thermal imaging has a lot more to offer than just a night vision solution for security applications.

In conclusion UAV borne thermal imaging is a promising method to retrieve highly resolved spatial information on the ground surface temperature within a short period of time.

5.4 Personal air vehicles (PAV)

Personal transportation is often preferred to the public transport and most of them have been made on the ground through roads. However, with the increasing traffic volume, the average time spent travelling on roads has significantly increased for the same amount of distance travelled. It has already been proposed that utilization of the possible third dimension of transportation system, which is the air transport, can facilitate in supporting the personal transportation and subsequently alleviate this problem. One solution to extend this limit is the concepts of the personal air vehicle (PAV) that is envisioned to operate synergistically with ground and air infrastructures.

Personal transportation has become a necessity in today's life. In addition to personal trips from one place to the other, transportation enables greater socioeconomic opportunities. An effective transportation means is vital for growing global and local businesses and networking, especially those involving door-to-door and face-to-face service. As time progresses, the personal transportation system also needs to be improved to suit with the changing travel demands and requirements. It is anticipated that future personal travels will emphasize more on having door step-to-destination journeys at any time, in any weather and in as little travel time as possible. In general, the ability of an individual to travel can be taken to be mainly constrained by two factors: time and money. These factors play a vital role in determining the preferred mode of transportation through their trade-offs.

Transporting people from a hub to a variable location, or taxi-like deliveries where drones can pick up people at a variable location and drop them off at another. The pick-up and drop off locations will have huge implications on required infrastructure, route planning, security, and regulation. For passenger-carrying drones the safety of passengers and people on the ground will be paramount. The infrastructure around the drones will have to be carefully designed and integrated within existing urban systems, this will include take-off and landing infrastructure, as well as servicing and maintenance points. Advantages of using PAVs to transport people include reduced congestion on city roads, improved mobility of people around a city, and reduced strain on existing public transport networks. Personal transportation is often preferred to the public transport and most of them have been made on the ground through roads. However, with the increasing traffic volume, the average time spent travelling on roads has significantly increased for the same amount of distance travelled. It has already been proposed that utilization of the possible third dimension of transportation system, which is the air transport, can facilitate in supporting the personal transportation and subsequently alleviate this problem. One solution to extend this limit is the concepts of the personal air vehicle (PAV) that is envisioned to operate synergistically with ground and air infrastructures.

Personal transportation has become a necessity in today's life. In addition to personal trips from one place to the other, transportation enables greater socioeconomic opportunities. An effective transportation means is vital for growing global and local businesses and networking, especially those involving door-to-door and face-to-face service. As time progresses, the personal transportation system also needs to be improved to suit with the changing travel demands and requirements. It is anticipated that future personal travels will emphasize more on having door step-to-destination journeys at any time, in any weather and in as little travel time as possible. In general, the ability of an individual to travel can be taken to be mainly constrained by two factors: time and money. These factors play a vital role in determining the preferred mode of transportation through their trade-offs.

Transporting people from a hub to a variable location, or taxi-like deliveries where drones can pick up people at a variable location and drop them off at another. The pick-up and drop off locations will have huge implications on required infrastructure, route planning, security, and regulation. For passenger-carrying drones the safety of passengers and people on the ground will be paramount. The infrastructure around the drones will have to be carefully designed and integrated within existing urban systems, this will include take-off and landing infrastructure, as well as servicing and maintenance points. Advantages of using PAVs to transport people include reduced

congestion on city roads, improved mobility of people around a city, and reduced strain on existing public transport networks.

System model

The system incorporates several subsystems working in union for communication and control. The quadcopter uses a SBC running an embedded Linux operating system and uses a wireless router to receive commands and transmit data over a Wi-Fi connection. Its GPS location, as well as streaming video, is transmitted through the wireless connection as the quadcopter maintains flight. All of the maneuvering and stability management is controlled autonomously onboard the quadcopter. The four brushless motors on the quadcopter are controlled in real-time, enabling the quadcopter to maintain a steady hover without vibrating or spinning and to be able to navigate to its destination. The quadcopter uses 3-axis magnetometer, gyroscope, and accelerometer, in unison, for positional feedback as part of a stabilization algorithm. To send commands to the quadcopter the user can connect to it, through SSH, and send the GPS coordinates of the target. The quadcopter then maneuvers to the target and streams video of the location, then returns to the designated starting position. When the quadcopter is navigating in three dimensional spaces there are two different coordinate systems present. One is the body coordinate system, indexed 'b', which is affected by the motors. The other is the navigation frame, indexed 'n', where forces like gravitation has influence. The body coordinate system will move along with the quadcopter, while the navigation coordinate system is the reference point for the quadcopter. The reference coordinate system can be placed anywhere, but has to be fixed once the quadcopter starts moving. One assumption for the coordinate systems is the neglected curvature of the earth. A quadcopter has a limited area to navigate in and this assumption will not affect any result. In avionics the Z-axis is normally pointing towards the earth. To ease the comparison with other projects the Z-axis is also pointing downwards in this project. The quadcopter is able to rotate around its own axes with an angular velocity. This angular velocity is denoted as $\dot{\sigma}$ with an index for the corresponding axis.

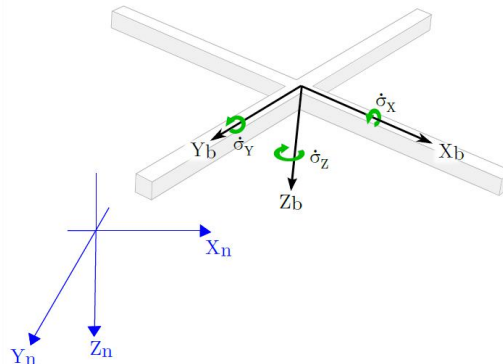

Fig 4: The blue coordinates are the navigation frame, while the black is the body coordinates

In order to get the orientation of the quadcopter in terms of angles, the quadcopters coordinate system has to be linked to the navigation coordinates. The way this is done is by the implementation of Euler angles. There are three Euler angles, ϕ , θ and ψ , known as roll, pitch and yaw. This notation is often used in avionics.

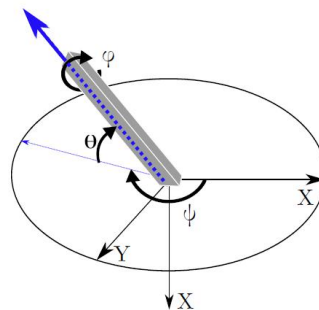

Fig 5.4.1: Euler angles

- b - Referred to body frame, onboard.
- n - Referred to navigation frame, fixed
- σ - General angle
- $\dot{\sigma}$ - General angular velocity
- ϕ - Euler angle for the roll
- θ - Euler angle for the pitch
- ψ - Euler angle for the yaw
- \underline{C}_{u}^v - Transformation matrix from u-frame to v-frame

ii) Forces

To start setting up a dynamic model, the most basic thing is to map which forces is acting on the module.

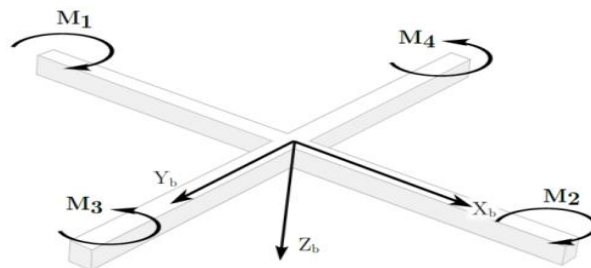

Fig 5.4.2: Sketch of where the motors are mounted and direction of propeller movement

Each motor have its own force acting in negative direction and also a moment that is acting in the opposite direction of the rotation of the motors.

The motors rotation and position is also of significant. Motor one and two are placed along the X-axis and rotate the in the clockwise direction. Motor three and four are placed on the Y-axis and rotate in the counter clockwise direction. Quaternion is not taken into consideration. source google

a) Mass and Acceleration

Newton first law gives us,

$$\underline{F}_{mass} = m_{total} * \begin{bmatrix} \ddot{X}_b \\ \ddot{Y}_b \\ \ddot{Z}_b \end{bmatrix}$$

b) Gravity

The gravity vector, F_g , is pulling the quadcopter in positive z-direction in the navigation frame. It can be represented in the body frame by multiplying the vector by the transformation matrix:

$$\underline{F}_{gb} = m_{total} \underline{C}_n^b \begin{bmatrix} 0 \\ 0 \\ g \end{bmatrix}$$

$$\underline{F}_{gb} = m_{total} * g * \begin{bmatrix} \sin(\theta) \\ -\sin(\phi) \cdot \cos(\theta) \\ \cos(\phi) \cdot \cos(\theta) \end{bmatrix}$$

c) Propeller Thrust

The force from the propellers are assumed that always will be parallel to the Z-axis in the body frame; hence there will be no force in the X- and Y-direction. This assumption yields only if the propeller is a rigid body with no flapping. In real life this is not the case, but the flapping is neglected from the equation. The generated thrust is a function of the propeller dimensions, and the rpm.

$$\underline{F}_{thrust} = \begin{bmatrix} 0 \\ 0 \\ F_{M1} + F_{M2} + F_{M3} \end{bmatrix}$$

\underline{I} = Inertia Matrix

a) *Thrust Moment*

The \underline{M}_{thrust} is a part of the external moments acting on the system, described by the propeller thrust F_{thrust} and the distance 'l' from CG to the center of the propeller:

$$\underline{M}_{thrust} = \begin{bmatrix} M_X \\ M_Y \\ M_Z \end{bmatrix}$$

$$M_X = (F_4 - F_3) \cdot l$$

$$M_X = (F_2 - F_1) \cdot l$$

$$M_X = (-F_1 - F_2 + F_3 + F_4) \cdot T_q$$

T_q is a constant which converts the thrust into moment.

b) *Motor Inertia Moment*

The motor and propeller angular velocity is causing a moment when the quadcopter is being tilted. Since the motor is only spinning parallel to the Z-axis the force can be described as:

$$\underline{M} = \underline{\omega}_{motor} * \underline{\dot{\sigma}} \cdot \underline{I}_{motor}$$

$$\underline{M}_{motor\ inertia} = \begin{bmatrix} 0 \\ 0 \\ \omega_{pi} \end{bmatrix} * \begin{bmatrix} \dot{\sigma}_x \\ \dot{\sigma}_y \\ \dot{\sigma}_z \end{bmatrix} \cdot \underline{I}_{motor}$$

$$\underline{M}_{motor\ inertia} = \begin{bmatrix} -\dot{\sigma}_y \cdot \omega_{pi} \\ \dot{\sigma}_x \cdot \omega_{pi} \\ 0 \end{bmatrix} \cdot \underline{I}_{motor}$$

Where the 'i', denotes the motor number. There should be noted that motors three and four rotates counterclockwise and thereby a negative angular velocity. Summing for all four motor gives:

$$\underline{M}_{pi} = \begin{bmatrix} -\dot{\sigma}_y \cdot (\omega_{p1} + \omega_{p2} + \omega_{p3} + \omega_{p4}) \\ \dot{\sigma}_x \cdot (\omega_{p1} + \omega_{p2} + \omega_{p3} + \omega_{p4}) \\ 0 \end{bmatrix} \cdot \underline{I}_{motor}$$

c) *Quadcopter Inertia*

The inertia matrix is given by:

$$\underline{I} = \begin{bmatrix} I_{11} & -I_{12} & -I_{13} \\ -I_{21} & I_{22} & -I_{23} \\ -I_{31} & -I_{32} & I_{33} \end{bmatrix}$$

d) *Moment Equations*

$$\underline{M}_{thrust} + \underline{M}_{motor\ inertia} = \underline{I} \cdot \underline{\ddot{\sigma}} + \underline{\dot{\sigma}} \times (\underline{I} \cdot \underline{\dot{\sigma}})$$

$$\underline{\ddot{\sigma}} = \underline{I}^{-1} \cdot (\underline{M}_{thrust} + \underline{M}_{motor\ inertia} - \underline{\dot{\sigma}} \times (\underline{I} \cdot \underline{\dot{\sigma}}))$$

e) *Euler rates*

The local angular velocities are related to the Euler angles by,

$$\begin{bmatrix} \dot{\phi} \\ \dot{\theta} \\ \dot{\psi} \end{bmatrix} = \frac{1}{\cos(\theta)} \begin{bmatrix} \cos(\psi) & -\sin(\psi) & 0 \\ \cos(\theta) \sin(\psi) & \cos(\theta) \cos(\psi) & 0 \\ -\sin(\theta) \cos(\psi) & \sin(\theta) \sin(\psi) & \cos(\theta) \end{bmatrix} \cdot \begin{bmatrix} \dot{\sigma}_X \\ \dot{\sigma}_Y \\ \dot{\sigma}_Z \end{bmatrix}$$

From this equation the angular velocities used is found. Hence the transformation matrix will be updated for every loop iteration.

Attitude and position estimation

i) Attitude Estimation

The IMU is strapped down to the quadcopter and measuring acceleration and angular velocity for the body coordinate system on the quadcopter. For a single axis system the attitude can easily be determined by for instance a first order complimentary filter where the gyro is being integrated. But for a multi axis system the attitude cannot be determined that easily because the attitude is dependant of the sequence of the rotation.

The attitude estimator chosen is a complementary filter. This is the most common filter used on UAV's. It provides a robust tradeoff between a good short term precision from the gyroscopes and a long term accuracy provided by accelerometers. This complementary filter is also proved asymptotically stable. The estimation of the DCM and the Euler angles from is divided into four sections.

1. Direction cosine from gyro signals
2. Renormalization of the DCM
3. Drift correction
4. Calculating the Euler angles

ii) Position Estimation

An important feature for an autonomous robot is its ability to know where it is at any time. There are several methods to solve position calculation, ranging from triangulation from known positions in the area to internal navigation system that calculates an approximated position with the help from onboard sensors.

Global Positioning System

GPS is a good method to use while moving outdoors. The information is gathered from satellites and calculated to give the current position of the receiver. Information of position, heading and velocity can easily be calculated and used to verify the robots current position.

The quadcopter has been fitted with a GPS module. As the plan for this project at this stage is to fly indoor the GPS was merely mounted to the quadcopter for later use. Even though the GPS is not used in the control system, a program was made to read the information from the GPS to make sure the module was working properly.

Control system

The main purpose of the control system is to control the quadcopter at given Euler angles, phi, theta and Psi. A position control will be an improvement but is not implemented. The position controller can calculate different position set points for the angle controller described in this chapter and the total motor thrust, and hence work independent of the angle controller.

i) Quadcopter Propeller Direction

When the quadcopter is hovering, all four propellers are spinning at the same RPM and are providing enough thrust to lift the aircraft

- a) **Yaw** – This is the rotating or swiveling of the head of the quadcopter either to right or left. It is the basic movement to spin the quadcopter. On most drones, it is the achieved by using the left throttle stick either to the left or right.

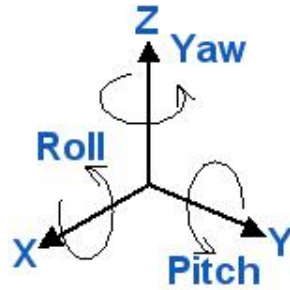

Fig 5.4.4: Propeller Direction

b) Pitch – This is the movement of quadcopter either forward and backward. Forward Pitch is achieved generally by pushing the throttle stick forward, which makes the quadcopter tilt and move forward, away from you. Backward pitch is achieved by moving the throttle stick backwards.

c) Roll – Most people get confused with Roll and Yaw. Roll is making the quadcopter fly sideways, either to left or right. Roll is controlled by the right throttle stick, making it fly either left of right.

- To pitch forward, the front two propellers (1 & 2) would spin at a slower rate than the back two propellers (3 & 4) would; this can be achieved by decreasing the RPM of the front two propellers and/or increasing the RPM of the back two propellers.

To pitch backward, the front two propellers would spin at a faster rate than the back two propellers. To roll to the right, the left two propellers (1 & 4) would spin at a faster rate than the right two propellers (2 & 3) would; again, this would be achieved by increasing the RPM of the left two propellers and/or decreasing the RPM of the right two propellers.

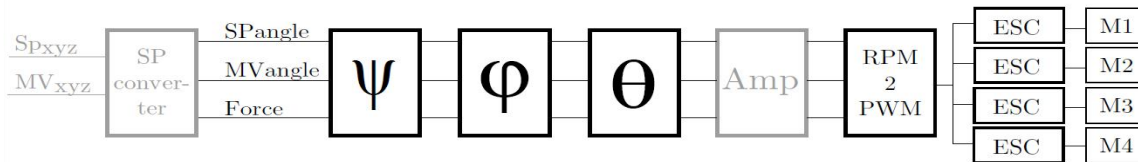

Fig 5.4.5: Main view of the control system, grayed out blocks is not in use

- To pitch to the left, the left two propellers would spin at a slower rate than the right two propellers. To yaw left, which would rotate the aircraft in a counterclockwise direction, propellers 1 & 4 would increase their RPM, while propellers 2 & 3 would decrease their RPM by the same amount.

The following equations calculate the maximum propeller tip speed and the maximum rotational speed of the propeller, respectively, where C_{prop} is the circumference of the circle made by the tips of the propeller as it rotates.

$$Power = Prop_{const} \cdot rpm^{power\ factor}$$

The shape of the propeller also changes performance; propellers with sharper blade tips are often more efficient, but those with flatter tips produce more thrust. Another factor to take into consideration is the number of blades on the propeller

Calculating static thrust is determining the power transmitted by the motors to the propellers in terms of rpm. The thrust, T produced by a propeller

$$T = \frac{\pi}{4} D^2 \rho v \Delta v$$

- D = Propeller diameter
- ρ = Density of air
- v = Velocity of the air at propeller
- Δv = Velocity of air accelerated by the propeller

The power that is absorbed by the propeller from the motor

$$P = \frac{T\Delta v}{2}$$

Mass of quadcopter is directly related to the mass of the aircraft. In particular, a thrust (mass) that equals the mass of the quadcopter is needed for hovering.

From Newton's law $F = ma$;

$$m = \frac{\left[\frac{\pi}{2} D^2 \rho P^2\right]^{1/3}}{g}$$

Where $g = 9.18 \text{ m/s}^2$.

A propeller's efficiency is determined by,

$$\eta = \frac{\text{Propulsive Power Out}}{\text{Shaft Power In}}$$

$$= \frac{\text{Thrust} \cdot \text{Axial Speed}}{\text{Resistance Torque} \cdot \text{Rotational Speed}}$$

i) *Yaw-controller*

The total motor thrust is set as a variable. This thrust is the thrust that is required to hoover or to accelerate the quadcopter in the local Z-axis. The more thrust, the faster the quadcopter will accelerate. But the yaw is controlled by altering the motor thrust between the four motors. The yaw controller divides the total force to the two motor pairs, 1-2 and 3-4. This way the total force is kept constant and a moment is applied to yaw, the quadcopter around the body Z-axis.

Since the relationship of the motor thrust and moment is constant the quadcopter will not yaw as long as the total thrust is equal for the two motor pairs.

ii) *Phi-Theta controller*

The phi and theta controller is the controller that controls the phi and theta angle of the quadcopter. This is done by dividing the motor pair force from the yaw controller to the two motors. This is done in two steps, first the phi angle is corrected, then theta. Both of them use the same controller.

The total force from the yaw controller which the motor pair is to put out, F_z , is the force that is divided by the two motors. For one of the motors the force factor is increased, and for the other motor the force is decreased by the same value, namely ΔF . The difference of the two motor forces creates a moment which will correct the angular error. At first ΔF is calculated by the angle error of the angle set point and the measured angle in addition to a gain. To put a damper to the regulator ΔF is reduced with the angular velocity around the given axis. This way the moment will be reduced with an increased angular velocity and will slow down the system.

Benefits of passenger drone

- Decongest road traffic
- Decrease pollution due to road traffic considerations
- Reduce transport time
- Provide quicker services in an emergency (e.g. air ambulance)
- More flexibility
- Evading accidents

Conclusion

A number of significant technology advances across many areas of expertise are required prior to the ability of PAVs to provide a benefit to a more significant portion of the public, than current General Aviation aircraft. With the results obtained from the PAV sector research activities, significant progress was made across many of the critical required capabilities. Working across many technology disciplines, this research is providing support for improved aerodynamics, quiet propulsion, zero emission engines, lower cost certification, lower cost structures, and the ability to understand the societal and airspace needs as these vehicle technologies bring about a new age in on-demand aviation. Much of this PAV research is also directly attributable to future UAV and military mission needs.

UAVs will soon take on be an imperative existence in the coming future. They will be seen taking up larger roles for a variety of jobs including business in the immediate future.

VI. PART SPECIFICATION SHEET

Payload	Frame	Propeller	Motor	ESC	Flight time	Battery
200g	Carbon fiber 200mm	5045	2205 BR2205 2300KVx4	20A Opto 2- 4S	8min	3s 3000mah
1kg	Carbon fiber 650mm	1555	4114/320KV x4	40A Opto 6s	45 min	6s 16000mAh
15kg	Carbon fiber 1500mm	1755	5008/340KV x8	40A Opto 6s	16 min	6s 22000mah
150kg	Aluminium	3211	P80 KV100 x16	200A	-	12s 100Ah

VII. TESTING AND DEMONSTRATION

7.1 Demonstration to Kerala Police Department



7.2 Testing and demonstration to Kerala Forest Department



7.3 Tracking human for Kerala Forest Department



7.4 Tracking wildlife for Kerala Forest Department



7.5 Tracking wildlife for Kerala Forest Department



7.4 Tracking crowd for Kerala Forest Department



7.5 Disaster management –Delivering life supply, human tracking.



7.6 Intruder drone detection using computer vision based on machine learning

8 x 38 x 512	->	38 x 38 x 512	
8 x 38 x 512	->	19 x 19 x 1024	3.407 BFLOPs
9 x 19 x 1024	->	19 x 19 x 512	0.379 BFLOPs
9 x 19 x 512	->	19 x 19 x 1024	3.407 BFLOPs
9 x 19 x 1024	->	19 x 19 x 1024	
9 x 19 x 1024	->	19 x 19 x 512	0.379 BFLOPs
9 x 19 x 512	->	19 x 19 x 1024	3.407 BFLOPs
9 x 19 x 1024	->	19 x 19 x 1024	
9 x 19 x 1024	->	19 x 19 x 512	0.379 BFLOPs
9 x 19 x 512	->	19 x 19 x 1024	3.407 BFLOPs
9 x 19 x 1024	->	19 x 19 x 1024	
9 x 19 x 1024	->	19 x 19 x 512	0.379 BFLOPs
9 x 19 x 512	->	19 x 19 x 1024	3.407 BFLOPs
9 x 19 x 1024	->	19 x 19 x 1024	
9 x 19 x 512	->	19 x 19 x 1024	3.407 BFLOPs
9 x 19 x 1024	->	19 x 19 x 512	0.379 BFLOPs
9 x 19 x 512	->	19 x 19 x 1024	3.407 BFLOPs
9 x 19 x 1024	->	19 x 19 x 255	0.189 BFLOPs
9 x 19 x 512	->	19 x 19 x 256	0.095 BFLOPs
9 x 19 x 256	->	38 x 38 x 256	
8 x 38 x 768	->	38 x 38 x 256	0.568 BFLOPs
8 x 38 x 256	->	38 x 38 x 512	3.407 BFLOPs
8 x 38 x 512	->	38 x 38 x 256	0.379 BFLOPs
8 x 38 x 256	->	38 x 38 x 512	3.407 BFLOPs
8 x 38 x 512	->	38 x 38 x 256	0.379 BFLOPs
8 x 38 x 256	->	38 x 38 x 512	3.407 BFLOPs
8 x 38 x 512	->	38 x 38 x 255	0.377 BFLOPs
8 x 38 x 256	->	38 x 38 x 128	0.095 BFLOPs
8 x 38 x 128	->	76 x 76 x 128	

A photograph of a drone flying over a body of water. The drone is a quadcopter with a camera attached. A blue bounding box is drawn around the drone, and the word "Drone" is written in blue text above the box. The background shows a blurred view of the water and a distant shoreline.

7.7 Aerial 3D survey of residential area DSM from pix4dmapper

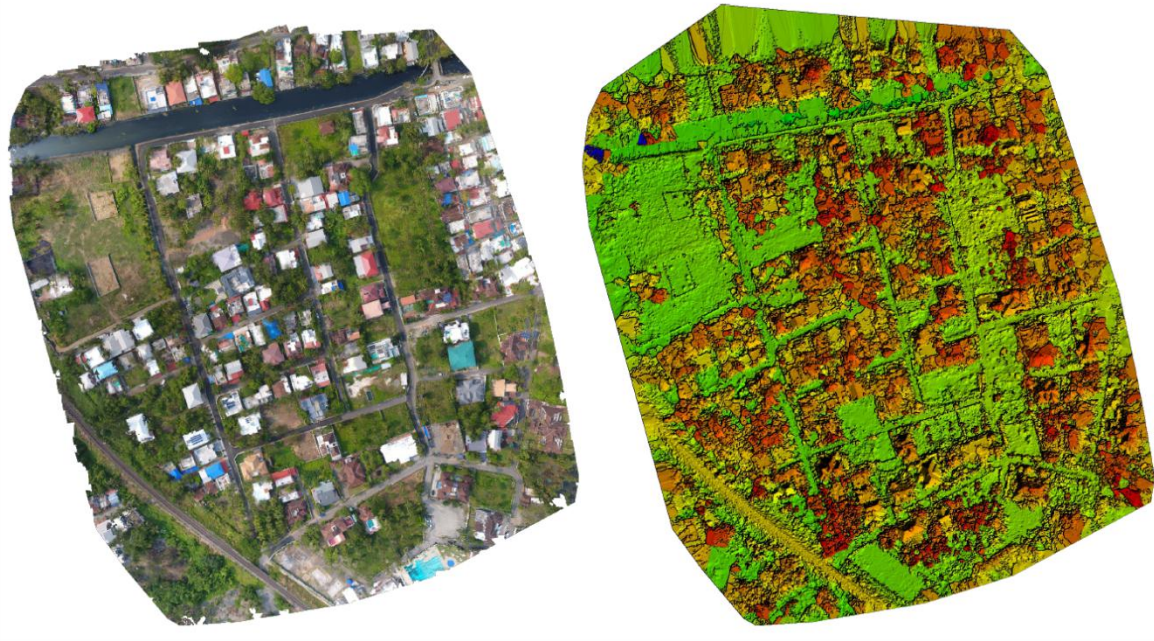

7.7 Aerial 3D flood mapping for Archeology department DSM from pix4dmapper

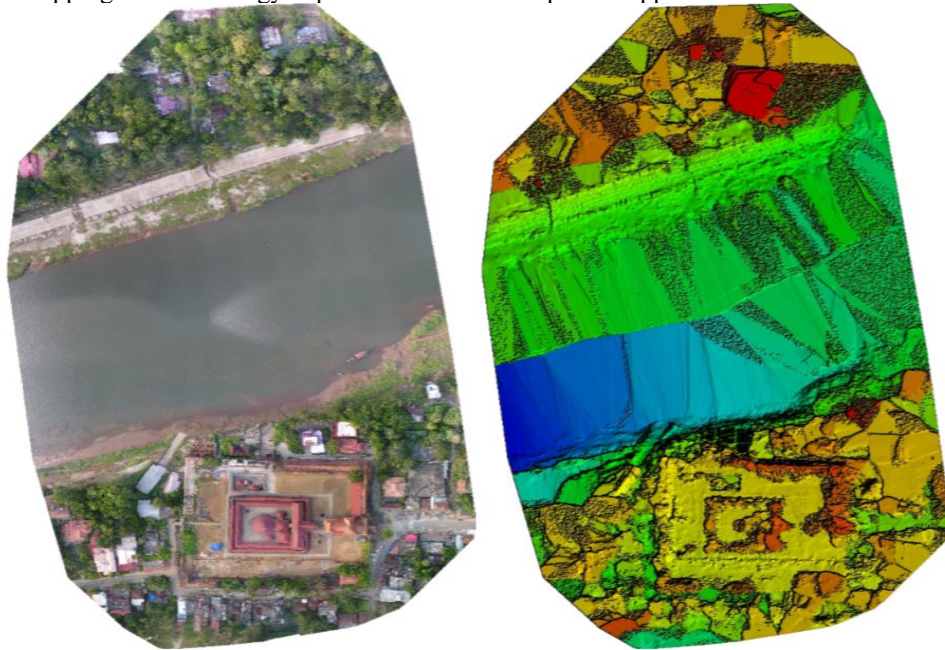

VIII. CONCLUSIONS

- Developed multicolor UAV system for precision agriculture, land surveying.
- Designed UAVs for payload up to 200g, 1kg and 15kg
- Incorporated GPS and IMU based autopilot, data link .
- Test the feasibility of using NDVI camera to measure the amount of live vegetation

- Test the feasibility of using thermal imaging for life-saving application.
- Incorporated a pay-load releasing mechanism from a remote control signal.
- Incorporated face detection and intruded UAV detection using machine learning.
- Designed a heavy payload human carrying aerial platform.

REFERENCES

1. Arigela, S. and K.V. Asari (2006). *An adaptive and non linear technique for enhancement of extremely high contrast images. In Applied Imagery and Pattern Recognition Workshop, 2006. AIPR 2006. 35th IEEE, oct.), pp. 24.*
2. Bourquardez, Odile, Robert Mahony, Nicolas Guenard and Francois Chaumette, Tarek Hameland and Laurent Eck (2009). *Image-based visual servo control of the translation kinematics of a quadrotor aerial vehicle. IEEE Transactions on Robotics 25, 743–749.*
3. Cabecinhas, D., C. Silvestre and R. Cunha (2010). *Vision-based quadrotor stabilization using a pan and tilt camera. 49th IEEE Conference on Decision and Control, 1644–1649.*
4. Cambron, M.E. and S.G. Northrup (2006). *Calibration of a pole-mounted camera using a neural network. In System Theory, 2006. SSSST '06. Proceeding of the Thirty-Eighth Southeastern Symposium on, march), pp. 265–269.*
5. Carvalho, Edwin John Oliveira (2008). *Localization and cooperation of mobile robots applied to formation control. Master's thesis, Instituto Superior Tecnico.*
6. Chhaniyara, Savan, Pished Bunnun, Lakmal D. Seneviratne and Kaspar Althoefer (2008). *Optical flow algorithm for velocity estimation of ground vehicles: A feasibility study. International Journal on Smart Sensing and Intelligent Systems 1.*
7. Couto, Miguel (2010). *Localizacao e navegacao entre robos moveis: Dissertacao de mestrado. Master's thesis, Av. Rovisco Pais, 1. 77*
8. Domingues, Jorge Miguel Brito (2009). *Quadrotor prototype. Master's thesis, Instituto Superior Tecnico.*
9. Fujikake, H., K. Takizawa, T. Aida, T. Negishi and M. Kobayashi (1998). *Video camera system using liquid-crystal polarizing filter to reduce reflected light. Broadcasting, IEEE Transactions on 44(4), 419 – 426.*
10. He, Kuen-Jan, Chien-Chih Chen, Ching-Hsi Lu and Lei Wang (2010). *Implementation of a new contrast enhancement method for video images. In Industrial Electronics and Applications (ICIEA), 2010 the 5th IEEE Conference on, june), pp. 1982–1987.*
11. Henriques, Bernardo Sousa Machado (2011). *Estimation and control of a quadrotor attitude. Master's thesis, Instituto Superior Tecnico.*
12. Ismail, A. H., H. R. Ramli, M. H. Ahmad and M. H. Marhaban (2009). *Vision-based system for line following mobile robot. IEEE Symposium on Industrial Electronics and Applications, 642–645.*
13. Otsu, Nobuyuki (1979). *A threshold selection method from gray-level histograms. Systems, Man and Cybernetics, IEEE Transactions on 9(1), 62–66.*
14. Romero, Hugo, Sergio Salazar, Rogelio Lozano, Member and IEEE (2009). *Real-time stabilization of an eight-rotor uav using optical flow. IEEE Transactions on Robotics 25, 809–817.*
15. Rondon, Eduardo, Luis-Rodolfo Garcia-Carrillo and Isabelle Fantoni (2010). *Vision-based altitude, position and speed regulation of a quadrotor rotorcraft. IEEE Interna, 628–633.*
16. Song*, Xiaojing, Lakmal D Seneviratne, Kaspar Althoefer, Zibin Song and Yahya H Zweiri (2007). *Visual odometry for velocity estimation of uavs. IEEE International Conference on Mechatronics and Automation, 1611–1616.*
17. Song, Xiaojing, Zibin Song, Lakmal D Seneviratne and Kaspar Althoefer (2008). *Optical flowbased slip and velocity estimation technique for unmanned skid-steered vehicles. IEEE International Conference on Intelligent Robots and Systems, 101–106.*
18. *Images from google, Wikipedia, pix4d*